



Webster Combustion Technology
619 Industrial Road, Winfield, KS 67156

Installation, Startup, Operation and Maintenance Manual

Model HDRS-RF Burner

For Gas, Oil and Combination burners

With and Without Low NOx IFGR

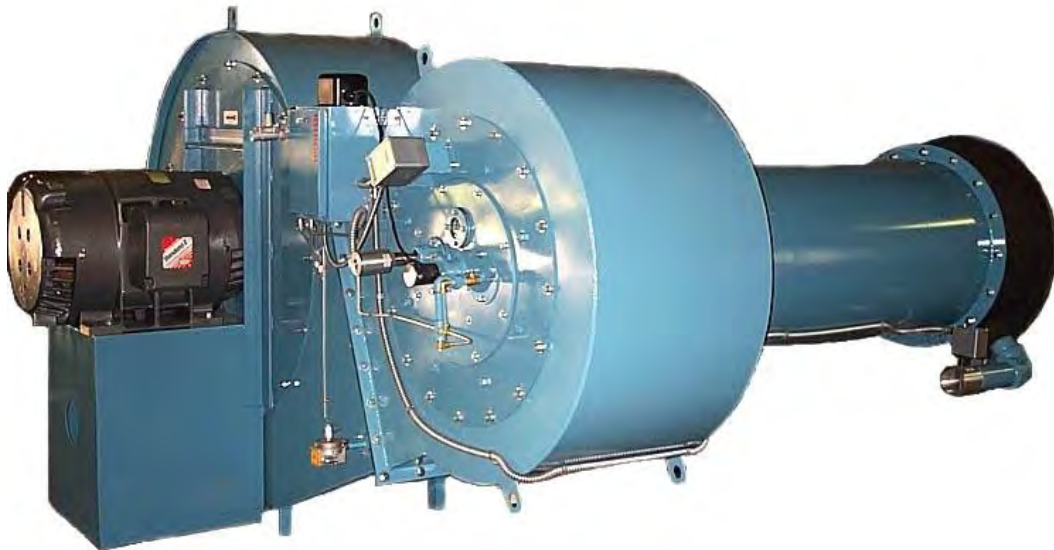

Manual Part No. 950062

www.webstercombustion.com

September, 2014

© 2014 All Rights Reserved

SAFETY PRECAUTIONS

Good safety practices must be used when working on burner equipment. The potential energy in the electrical supply, fuel and related equipment must be handled with extreme care to prevent equipment failures, injuries and potential death.

Throughout this manual, the following symbols are used to identify potential problems.

WARNING

This indicates a potential hazardous situation, which if not avoided, could result in personal injury or death.

CAUTION

This indicates a potentially hazardous situation, which if not avoided, could result in damage to the equipment.

The following general safety precautions apply to all equipment work.

WARNING

IF YOU SMELL GAS, OPEN WINDOW, EXTINGUISH ANY OPEN FLAMES, STAY AWAY FROM ELECTRICAL SWITCHES, EVACUATE THE BUILDING AND IMMEDIATELY CALL THE GAS COMPANY.

IN ACCORDANCE WITH OSHA STANDARDS, ALL EQUIPMENT, MACHINES AND PROCESSES SHALL BE LOCKED OUT PRIOR TO SERVICING.

IF THIS EQUIPMENT IS NOT INSTALLED, OPERATED AND MAINTAINED IN ACCORDANCE WITH THE MANUFACTURERS INSTRUCTIONS, THIS PRODUCT COULD EXPOSE YOU TO SUBSTANCES IN FUEL OR FROM FUEL COMBUSTION WHICH CAN CAUSE DEATH OR SERIOUS ILLNESS AND WHICH ARE KNOWN TO THE STATE OF CALIFORNIA TO CAUSE CANCER, BIRTH DEFECTS OR OTHER REPRODUCTIVE HARM.

IMPROPER SERVICING OF THIS EQUIPMENT MAY CREATE A POTENTIAL HAZARD TO EQUIPMENT AND OPERATORS.

SERVICING MUST BE DONE BY A FULLY TRAINED AND QUALIFIED PERSONNEL.

BEFORE DISCONNECTING OR OPENING UP A FUEL LINE AND BEFORE CLEANING OR REPLACING PARTS OF ANY KIND,

- **TURN OFF THE MAIN MANUAL FUEL SHUTOFF VALVES INCLUDING THE PILOT COCK, IF APPLICABLE. IF A MULTIPLE FUEL BURNER, SHUT OFF ALL FUELS.**
- **TURN OFF ALL ELECTRICAL DISCONNECTS TO THE BURNER AND ANY OTHER EQUIPMENT OR SYSTEMS ELECTRICALLY INTERLOCKED WITH THE BURNER.**

Service Organization Information:

Company Name _____

Address _____

Phone Number _____

Date of Startup

Lead Technician

Table of Contents

A. General	Page 4	G. Maintenance	Page 48
1. Nameplate Information	Page 4	1. General	Page 48
2. Ratings	Page 4	2. Physical Inspection	Page 48
3. Product Offering	Page 4	3. Fuel-Air-Ratio	Page 48
4. Your Complete Manual	Page 6	4. Gas Fuel Systems	Page 48
5. Service and Parts	Page 6	5. Oil Fuel Systems	Page 48
B. Components	Page 7	6. FGR Systems	Page 49
1. General	Page 10	7. Combustion Air Fan	Page 49
2. Combustion Air	Page 10	8. Inspection and Maintenance Schedule	Page 50
3. Burner Drawer	Page 11	9. Combustion Chart	Page 51
4. Gas Fuel Components	Page 12	H. Trouble Shooting	Page 53
5. Oil Fuel Components	Page 13		
6. Flue Gas Recirculation (FGR)	Page 14		
7. Fuel-Air-Ratio Controls	Page 15		
8. Electrical Controls	Page 16		
C. Installation	Page 18		
1. General Considerations	Page 18		
2. Refractory Frontplate	Page 19		
3. Burner Mounting	Page 19		
4. Gas Piping	Page 21		
5. General Oil Piping	Page 21		
6. Air Atomized #2 Oil	Page 22		
7. Heavy Oil	Page 22		
8. Gas Pilot	Page 23		
9. FGR Duct System	Page 23		
10. Draft and Stacks	Page 25		
11. Electrical System	Page 27		
D. Fuel and Control Systems	Page 28		
1. Gas Systems	Page 28		
2. Gas Pilot	Page 29		
3. Air Atomized #2 Oil	Page 29		
4. Heavy Oil	Page 29		
5. Fuel-Air-Ratio Controls	Page 30		
6. Electrical Controls	Page 30		
7. Operating and Modulating Controls	Page 30		
8. Flame Safeguards	Page 31		
E. Preliminary Adjustments	Page 33		
1. Visual Inspection	Page 33		
2. Burner Drawer Checkout	Page 33		
3. Motor Rotation	Page 34		
4. Fuel, FGR and Air Control	Page 35		
5. Fuel Cam Adjustments	Page 36		
6. Air Damper Adjustments	Page 37		
7. Pilot and Scanner Adjustments	Page 37		
8. Gas System Adjustments	Page 37		
9. Oil System Adjustments	Page 38		
10. Air Proving Switch	Page 38		
11. Operating and Modulating Controls	Page 38		
F. Startup and Operating Adjustments	Page 39		
1. Pre-Start Check List	Page 39		
2. Linkage Adjustments	Page 39		
3. Fuel Cam Adjustments	Page 40		
4. FGR Adjustments	Page 40		
5. Burner Drawer Adjustments	Page 41		
6. Single Fuel Setups	Page 41		
7. Combination Gas and Air			
Atomized #2 Oil	Page 41		
8. Combination Gas and Heavy Oil	Page 42		
9. Gas Setup	Page 42		
10. Air Atomized #2 Oil Setup	Page 43		
11. Heavy Oil Setup	Page 45		
12. Operating Control Adjustments	Page 46		
13. Limit Tests	Page 46		
14. Pilot Test	Page 46		
15. Burner Shutdown	Page 46		
16. Restart After Extended Shutdown	Page 47		

A. GENERAL

1. Nameplate Information
2. Ratings
3. Product Offering
4. Your Complete Manual
5. Service and Parts

This manual covers the Models HDRS-RF and HDRSX-RF burners offered by Webster Engineering & Manufacturing Co., LLC. The model designation "HDRS" is used to cover all version of this product line. These burners are intended for commercial and industrial applications on scotch marine firetube boilers. They can fire gas, oil or combinations of gas and oil.

READ AND SAVE THESE INSTRUCTIONS FOR REFERENCE

WARNING

DO NOT ATTEMPT TO START, ADJUST OR MAINTAIN THIS BURNER WITHOUT PROPER TRAINING OR EXPERIENCE. FAILURE TO USE KNOWLEDGEABLE TECHNICIANS CAN RESULT IN EQUIPMENT DAMAGE, PERSONAL INJURY OR DEATH.

The startup and maintenance of the HDRS-RF and HDRSX-RF burner requires the skills of an experienced and properly trained burner technician. Inexperienced individuals should not attempt to start or adjust this burner.

THE INSTALLATION OF THE EQUIPMENT SHALL BE IN ACCORDANCE WITH THE REGULATION OF AUTHORITIES HAVING JURISDICTION, INCLUDING THE NATIONAL ELECTRICAL CODE, CSA STANDARDS 139 AND 140, THE CANADIAN NATIONAL ELECTRIC CODE, PART I AND ALL LOCAL CODES.

Every attempt has been made to accurately reflect the burner construction, however, product upgrades and spe-

cial order requirements may result in differences between the content of this manual and the actual equipment. These special components will be described in the information provided with the burner and should be used as the controlling document.

NOTE: This manual must be readily available to all operators and maintained in legible condition.

1. Nameplate Information

Each burner has a nameplate with important job details, similar to the nameplates shown in Figure A-1.

The model number is defined in Figure A-2, and is used to describe the burner model, size, fuels and configuration. The model number appears on the Nameplate and BOM supplied with the burner.

The serial number represents the unique number for that burner and is a critical number that will be needed for any communications with Webster Engineering.

The input rates define the maximum and minimum inputs for that burner, given in MBH for gas and GPH for oil. For gas firing, the gas manifold pressure is given in "in wc" which is inches of water column.

The electrical ratings of the burner are given, with the voltage, current load, frequency and phase (this will either be single or 3-phase). For motors, the motor HP is listed.

2. Ratings

The general burner ratings are given in Figure A-3. The maximum and minimum inputs are given, based on the type of fuel. Other conditions, like the supply gas pressure or the combination of fuels, emission requirements and control systems may limit the turndown.

Turndown is defined as the ratio of the maximum input to the minimum input. For example, a burner with a maximum input of 120 GPH and a minimum input of 12 GPH has a 10:1 turndown. Burners equipped for high turndown (greater than 6:1) can have different equipment to improve fuel, air and FGR flow control.

3. Product Offering

The HDRS burner is intended for Scotch Marine Fire-tube boiler applications. The burner can fire natural gas, propane and digester gas as well as all grades of light and heavy oil (#2, #4, #5 and #6 oils as defined by ASTM D396).

DO NOT USE GASOLINE, CRANKCASE OIL OR ANY OIL CONTAINING GASOLINE.

This burner is also available as a low emission burner, and will have model designation HDRSX. The "X" in the HDRSX-RF refers to a low NOx burner, where FGR is used to reduce the NOx in the combustion gases. If the burner is not a low NOx burner, there is no X in the model.

Figure A-1 Nameplate

MODEL NUMBER		SERIAL NUMBER	
HDRS-RFC-2200 I-SL 1500-Mark6-M .4		U83586A-02	
JOB LOCATION		DATE MFG	
United Fuels		4-18-06	
GAS INPUT RATING		OIL INPUT RATING	
	MBTU/HR	IN.WC	GPH
MAXIMUM	92056	75	658
MINIMUM	27909206	0.15	110
		PSI	
		65/55	18/16
FUEL		#2 OIL / AIR	
NATURAL GAS		#2 OIL / AIR	
	VOLTS	AMPS	HERTZ
CONTROL CIRCUIT	115	5	60
BURNER MOTOR	460	169	60
OIL PUMP MOTOR	460	6	60
			PHASE
			1
			3
			3
			HP
			150
			5

MODEL HDRS(X) BURNER MODEL CONFIGURATION

FIGURE A-2

HDRS-RFC-2200I SL 1500 MARK6 -M .25 VGD -MA -UL/CSD-1

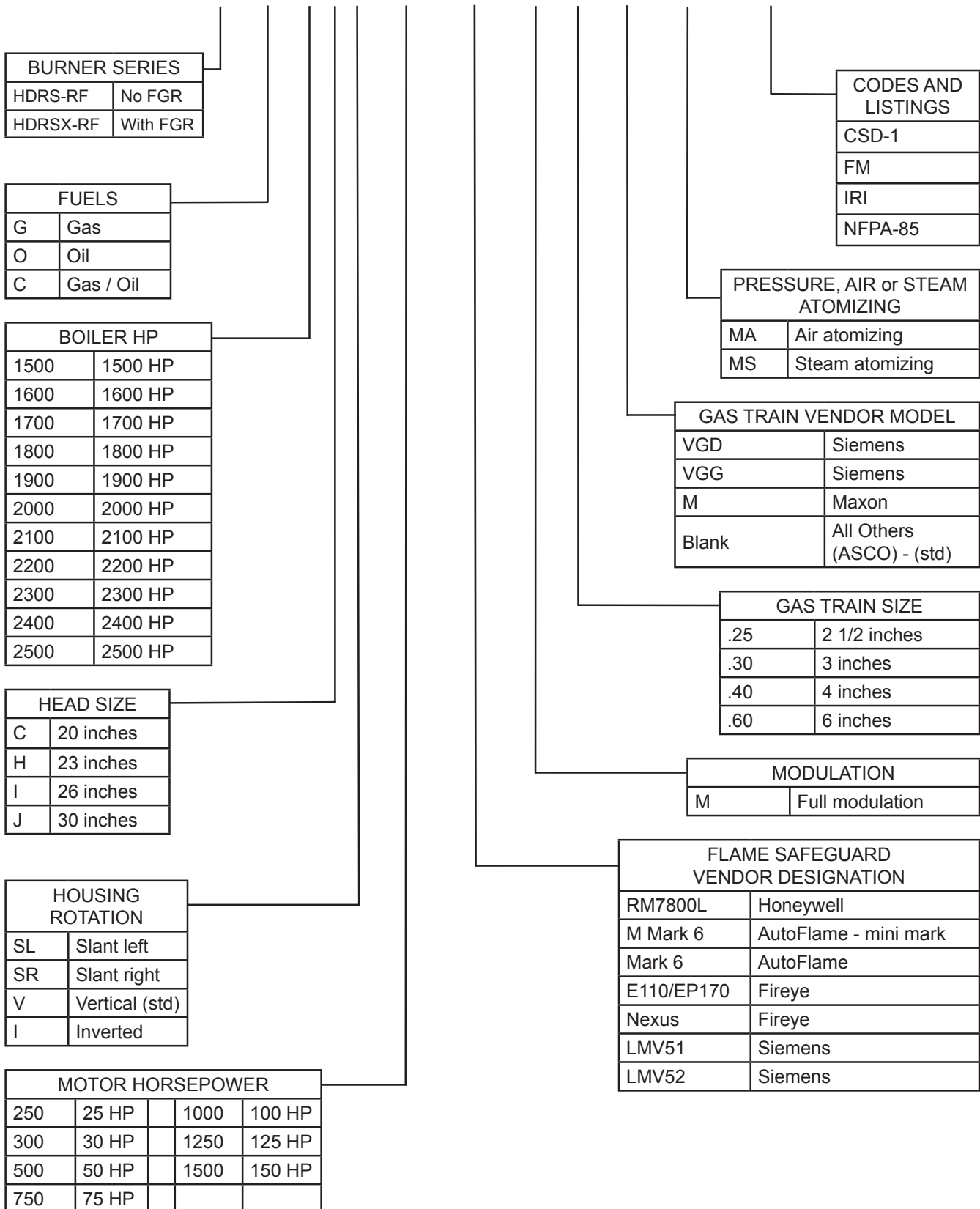

The above represents the common model designations.
Contact the factory for other options and special applications.

Several low NOx rates are available for all gas and light oil burners, with the standard offering of 60 ppm, 30 ppm when firing natural gas. Heavy oil is not allowed in combination with low NOx, as the high sulfur content can recirculate from the vessel through the burner when switched from heavy oil to gas. Low sulfur heavy oil can be used with gas FGR, when the sulfur is under ½% (the FGR is closed during oil firing).

Figure A-2 lists the common variations and options available on this product.

4. Your Complete Manual

In addition to this manual, there are several other documents that should be considered as part of the complete manual for the burner. All of these documents are needed to support the installation and startup of the unit. These additional items include:

- a. The wiring diagram, which shows the limits and interconnection of the burner and vessel controls.
- b. The gas and oil piping schematics, which show the components and their relative positions in the piping train.
- c. The unit material list which provides an overview of the burner requirements and a complete bill of material, including the part numbers and description for each item.
- d. The flame safeguard manual provides the operating sequence for the burner management system. This will be a critical document for troubleshooting any future problems.
- e. Catalog cuts of the major components. These provide

details on the installation, adjustment and maintenance of the components used on the burner.

5. Service, Parts and other Information

Service and parts are available from your local Webster Representative. For a list of Webster Representatives, please visit the Webster web site at:

www.webster-engineering.com or call 620-221-7464.

**Figure A-3
General Ratings**

BHP	Gas MBH		#2 Oil (GPH)		#6 Oil (GPH)	
	Min	Max	Min	Max	Min	Max
1200	5021	50213	60	359	67	335
1300	5440	54397	65	389	73	363
1400	5858	58581	70	418	78	391
1500	6277	62766	75	448	84	418
1600	6695	66950	80	478	89	446
1700	7113	71134	85	508	95	474
1800	7532	75319	90	538	100	502
1900	7950	79503	95	568	106	530
2000	8369	83688	100	598	112	558
2100	8787	87872	105	628	117	586
2200	9206	92056	110	658	123	614
2300	9624	96241	115	687	128	642
2400	10043	100425	120	717	134	670
2500	10461	104609	125	747	139	697

B. COMPONENT DESCRIPTIONS

1. General
2. Combustion Air
3. Burner Drawer
4. Gas Fuel Components

5. Oil Fuel Components
6. Flue Gas Recirculation (FGR)
7. Fuel-Air-Ratio Controls
8. Electrical Controls

This section describes the components of the HDRS (HDRS-RF and HDRSX-RF) burner line and provides some details on their application and operation. Other

sections of this manual provide a more detailed review of how the components work as a system and explain the overall operation of the burner.

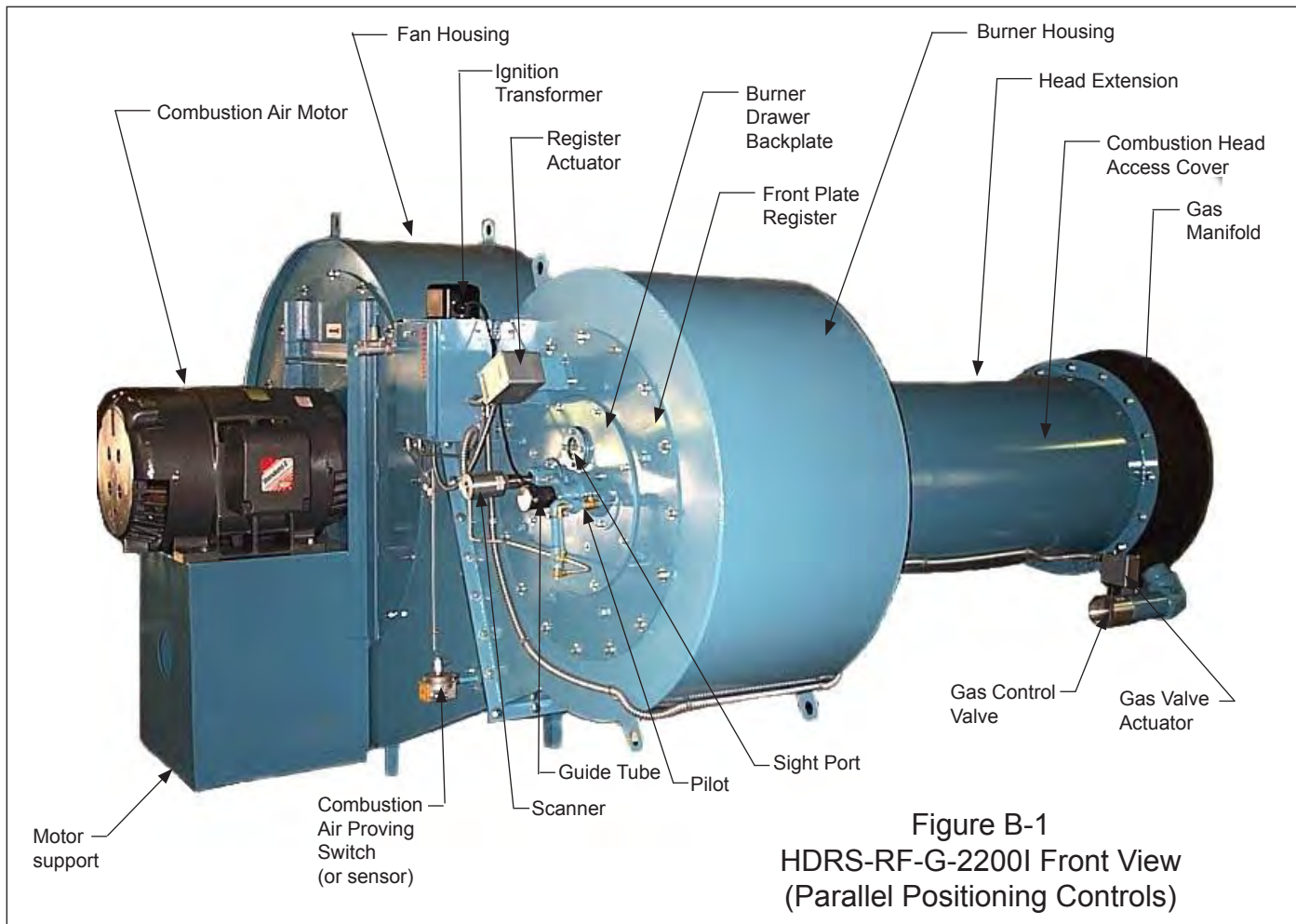

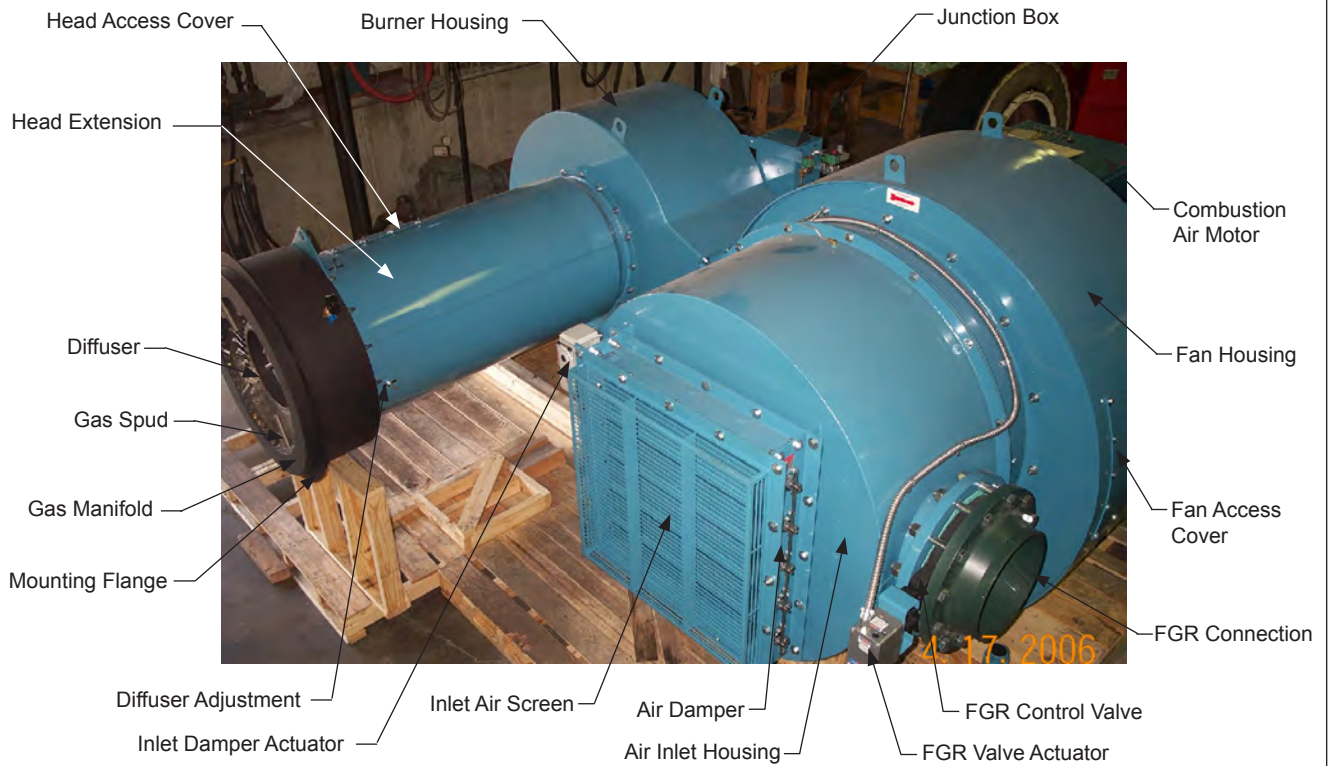

Figure B-2
HDRSX-RF-G-2200I Top View
(Parallel Positioning Controls)

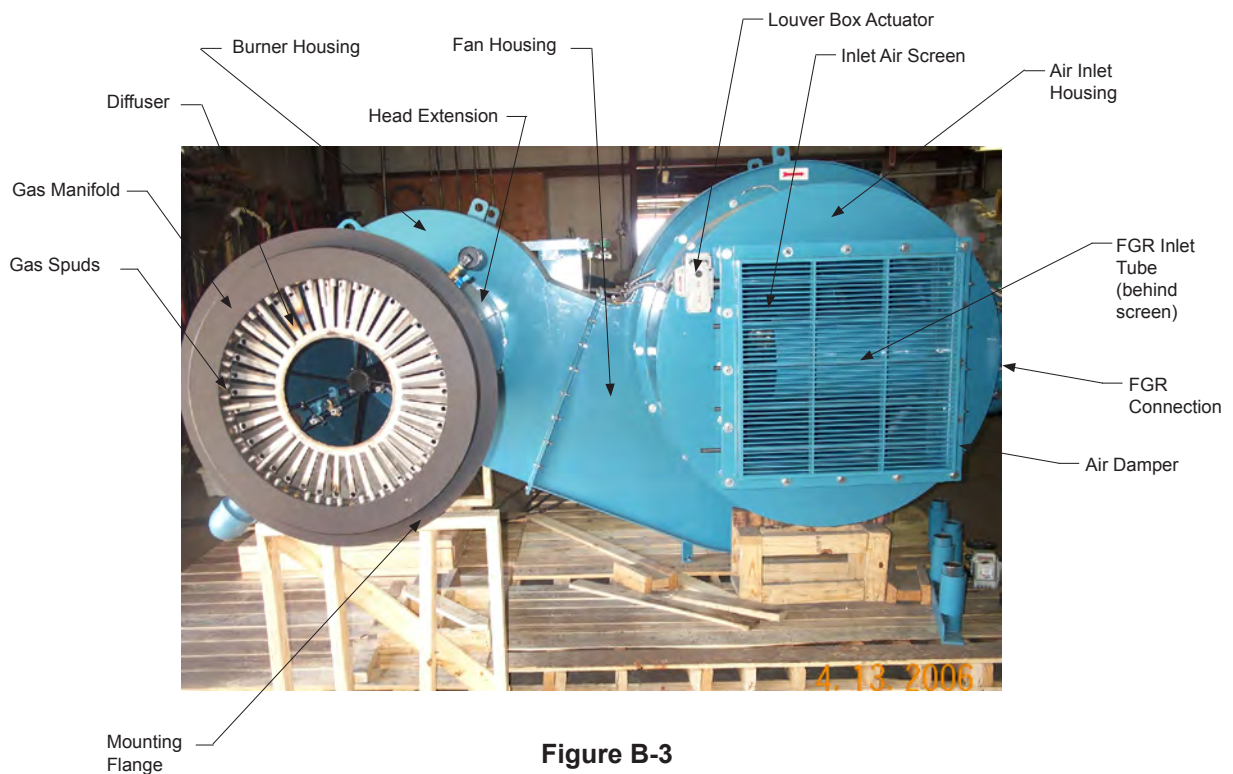
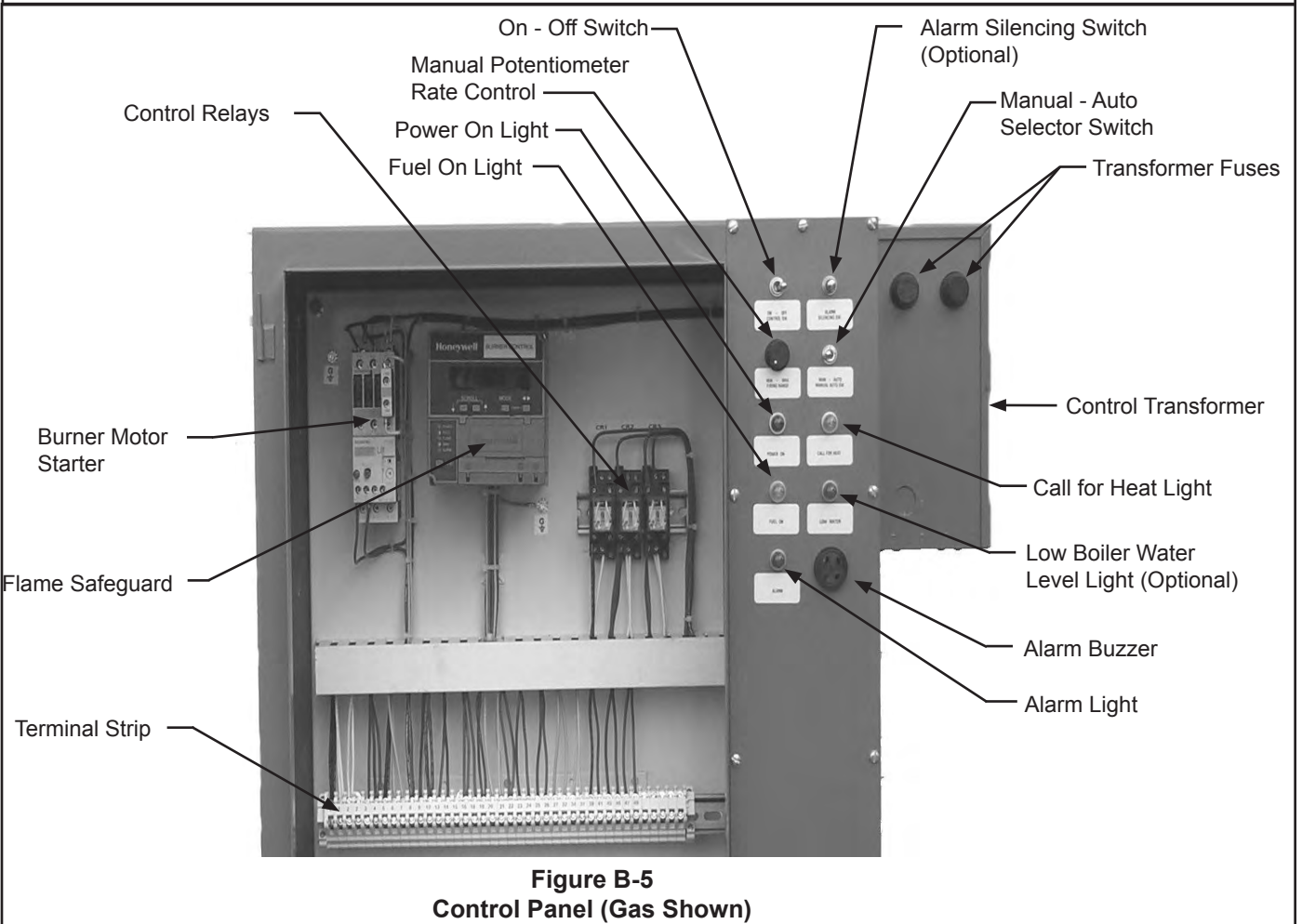
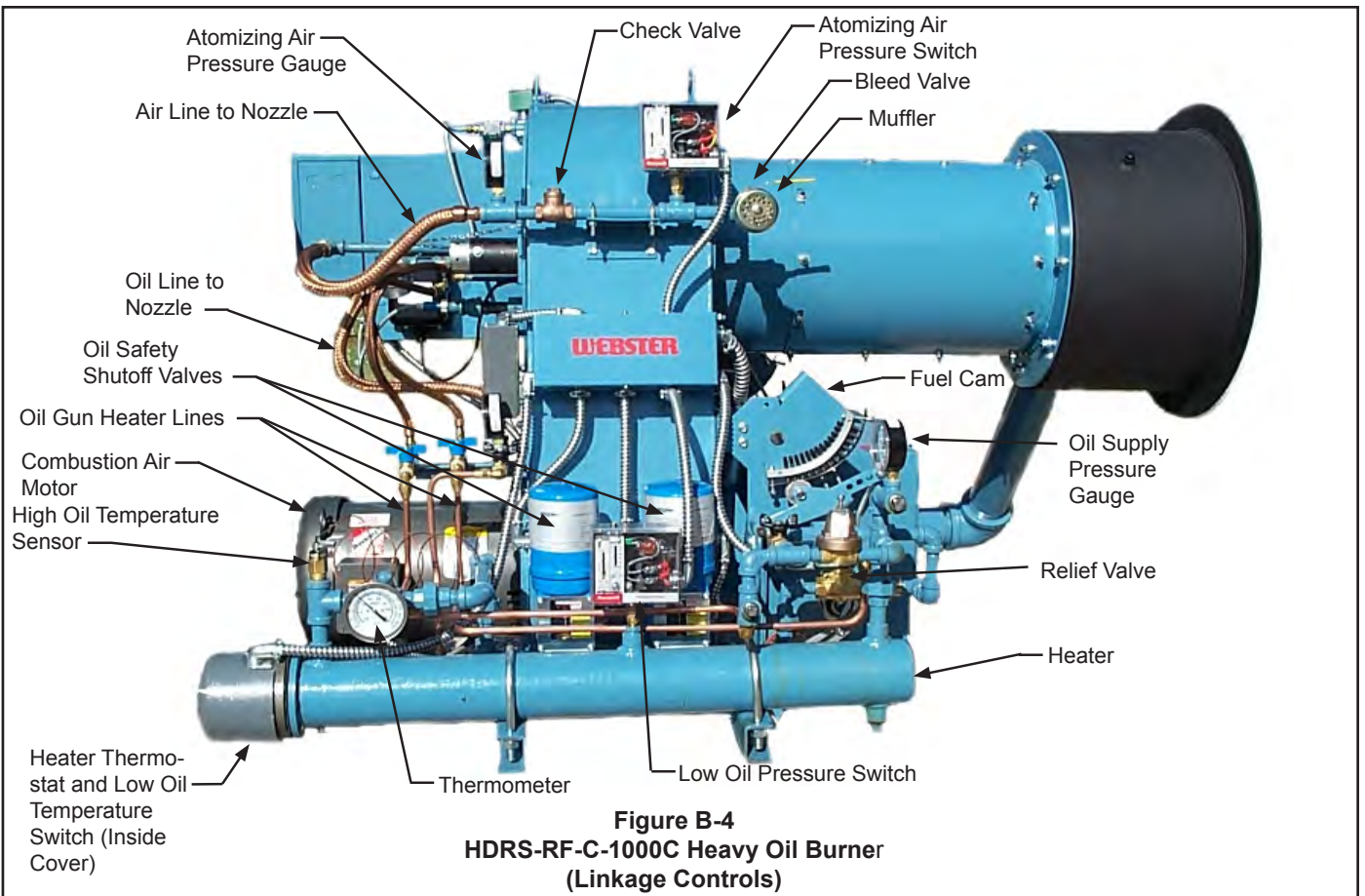

Figure B-3
HDRS-RF-G-2200I Rear View
(Parallel Positioning Controls)



1. General

The HDRS burner lines are configured from a common group of components that may vary in size and style depending on the capacity, NOx level, fuels and application. These common groups of components are described in this section, however the exact detail of any specific burner must be taken from the unit specific information provided with each burner. This would include the material list, wiring diagram, catalog cuts and fuel train drawings.

2. Combustion Air

Fan

A backward curved fan is used to supply the combustion air to burn the fuel. If the burner is equipped with FGR for low NOx, the fan will also provide the recirculated flue gas. The fan diameter and width will vary to match the required combustion air flow rate, FGR rate, burner altitude and vessel backpressure. The fan can operate at either 1750 or 3550 rpm. Generally, smaller burners operate at 3550 rpm and larger units operate at 1750 rpm, with the break point around 50,000 MBH.

The fan is mounted directly to the motor hub. It can be attached with a taper lock hub or it may have a hub that is machined to match the motor shaft diameter with set-screws used to lock the fan to the hub.

An inlet cone is used with the fan to provide a smooth air flow transition to the fan. Each fan has a matching inlet cone. In some cases, the inlet cone bolts directly to the housing and in other cases, it bolts to an adapter that bolts to the housing. The inlet cone should extend into the fan inlet about 1/4 inch.

Fan and Motor Assembly

The combustion air fan and motor are assembled together on a motor support plate that attaches to the windbox. The fan can be adjusted on the shaft to provide the correct overlap between the fan and inlet cone (any fan adjustments or assembly must follow the installation procedures for that fan arrangement).

All combustion air motors are braced to the floor to minimize vibrations. Larger motors (typically over 100 HP) are mounted on a box which is secured to the floor. Smaller motors are braced with pipe brackets..

Several different motor styles can be used depending on the application. An Open-Drip-Proof style is most common and used in a typical enclosed, clean environment. A TEFC (Totally Enclosed Fan Cooled) would typically be used in a dirty or wet environment. Other styles are also available for special applications. The motor dimensions, including the shaft diameter can vary by motor type.

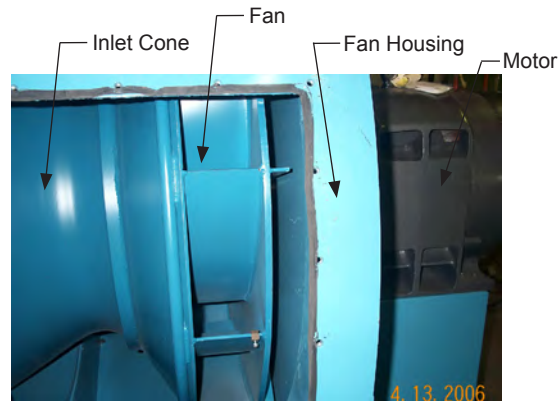

Fig B-6
Fan & Motor Assembly
(as viewed through access cover)

Fan Housing

The fan housing is an enclosure that routes the combustion air from the fan to the firing head and provides the primary mechanical structure for all of the components of the burner. The combustion air fan and inlet cone are contained within the fan housing. The burner housing attaches to the fan housing and the firing head is connected to the burner housing by the head extension. The FGR adapter and air damper are also connected to the fan housing opposite the combustion air motor.

There is an access door on the housing to gain access to the fan and inlet cone for inspection and balancing.

Burner Housing and Register

The burner housing connects the fan housing to the firing head, and contains the register and mounting for the burner drawer.

The register contains several rotating blades that are modulated to control the air flow and air mixing. The position of the registers change with the firing rate of the unit. In addition to regulating the air flow rate, they also impart a swirl to the air flow.

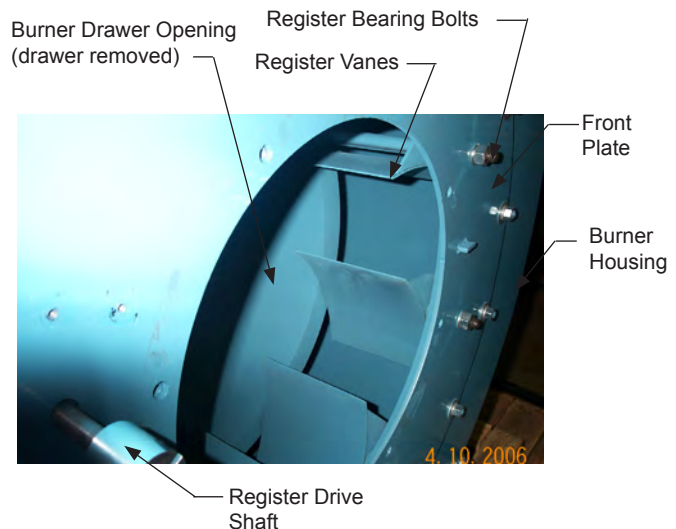

Fig B-7 Burner Register (Front View)

Head Extension

The head extension connects the firing head to the burner housing. It also allows different combinations of firing heads to be used with different fan and windbox sizes.

The head extension has an access door near the firing head to simplify inspection, adjustments and maintenance. The diffuser is removed through this opening. This can also be used to simplify gas spud changes.

Air Damper

The air damper regulates the flow of air to the burner. It has multiple blades used to control the air flow. The air damper is typically located on the inlet to the fan or at the outlet of the fan, between the windbox and burner housing.

On a single point positioning system (linkage), the damper shaft is connected by linkage to the jackshaft. On a parallel positioning system (linkageless), the shaft is directly coupled to the actuator for the air damper.

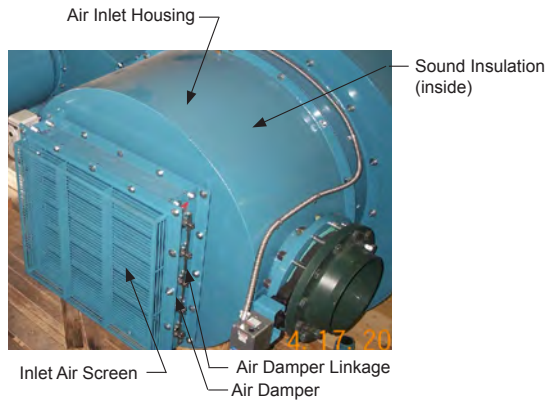

Figure B-8 Multi-blade damper

3. Burner Drawer

The burner drawer contains the pilot, scanner, guide tube and oil gun. These components are all attached to the backplate. The burner drawer can be removed as a complete unit for adjustment and inspection. The burner drawer slides through the burner housing and head extension and into the head. It is attached to the burner by bolting the backplate to the windbox.

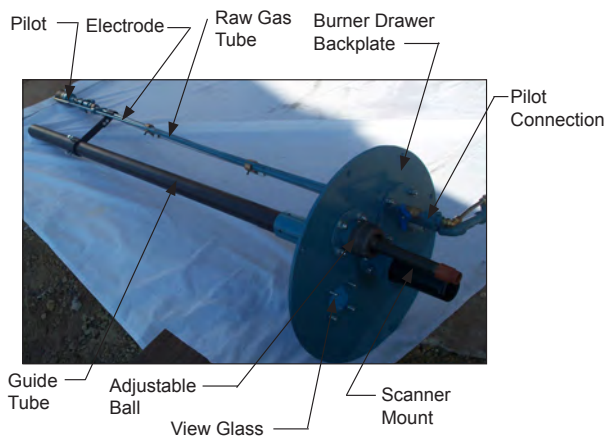

Figure B-9 Burner Drawer Assembly

The oil gun position can be adjusted (in and out) by sliding the oil gun through the guide tube. Setscrews are used to lock these tubes into position. The oil gun can be removed for inspection or extended gas firing without removing the burner drawer. The scanner is adjustable by way of its ball and swivel mounting.

Diffuser

The diffuser provides the directional control of the combustion air for mixing and combustion stability. The diffuser uses a combination of outer swirl air and inner straight air. An inner ring is fastened to the diffuser in some applications.

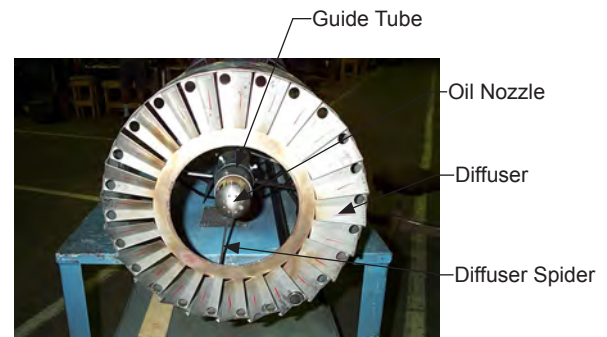

Figure B-10 Diffuser

The diffuser is mounted to the head extension and can be adjusted by loosening the mounting bolts on the head extension. The diffuser is also attached to the guide tube, and can be adjusted by moving the guide tube with the extension bolts loose. The fin opening and hole diameter can vary within a burner size, depending on input and NOx level.

Scanner

The scanner is an electronic sensor that detects the flame and acts as a safety switch with the flame safeguard. It is aligned to see the end of the pilot flame and the main flame on both gas and oil. The scanner is mounted on an adjustable ball and views the flame through a pipe. This allows the scanner to be positioned to see the end of the pilot, which ignites the main flame.

Pilot

The pilot uses a machined casting to provide a venturi to pull-in air and mix the gas and air prior to burning. A perforated screen is used on the outlet of the venturi to shield the base of the pilot flame from high velocity air. A raw gas tube is used to provide additional gas to the pilot and generate the proper pilot flame size. The ignition electrode provides a spark within the perforated screen to ignite the pilot flame.

The pilot is positioned about 3 inches behind the diffuser, so that the pilot flame passes through the diffuser to ignite the main flame. The pilot should never be operated for long time intervals (over 60 seconds) as it can damage the diffuser.

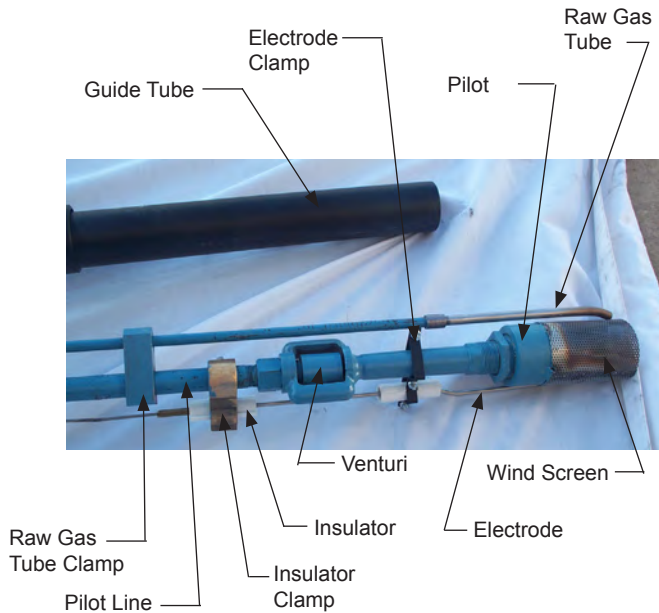

Figure B-11 - Pilot

4. Gas Fuel Components

Gas Train

The gas train contains the safety shut-off valves, manual shut-off valves, pressure switches and other components that may be required for the specific installation, available

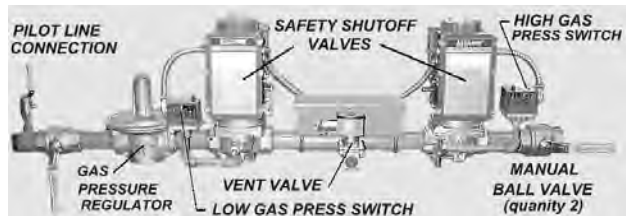

Figure B-12 Typical Gas Train

gas pressure, insurance codes and local regulations. The details of the gas train can vary greatly from burner to burner. Gas trains tend to be designed for each application and a unit specific gas train assembly drawing is provided for each unit, identifying the major components. Details are provided in the burner manual included with each burner.

The gas train shown in Figure B-12 uses a gas pressure regulator upstream of two safety shutoff valves. Another common style is to have the gas pressure regulation built into the second safety shutoff valve. (See Figure D-1)

Gas Safety Shutoff Valve

Each gas train has two shutoff valves in the gas train. These shutoff valves are motorized to open and spring return to close. They may contain a proof of closure switch to prove that the valve is in the closed position prior to starting the burner.

High Gas Pressure Switch

This switch is located after the last shutoff valve and before the gas flow control valve. It is set at a pressure that is greater than the highest gas pressure expected at this location. If the gas pressure rises above this level, it will trip

the switch and cause the burner to shut down.

Low Gas Pressure Switch

This switch is located before the first shutoff valve. It is set to a pressure that is below the expected gas pressure at this location. If the gas pressure falls below this setting, the switch will trip and cause the burner to shut down.

Gas Pressure Regulator

Each gas train must have a gas pressure regulator. The regulator insures a consistent supply pressure to the burner. Often the gas pressure regulator is the first item in the gas train or can be integrated into the second shutoff valve.

Gas Control Valve

The gas control valve is used to modulate the flow of gas fuel to the burner. On a single point positioning system (linkage), it is connected to the jackshaft and uses a fuel cam to make fine adjustments to fuel flow. With a parallel positioning system (linkageless), an actuator is connected to the gas control valve, and modulated by electronic control to the desired position. The gas control valve is located on the pipe that connects to the gas manifold.

Gas Manifold

The gas manifold (figure B-13) is a cylindrical chamber that has radial gas ports used to direct the gas fuel. Gas spuds are installed in these radial ports to improve the distribution of the gas. The gas manifold also holds the diffuser, which fits tightly into the gas manifold. This centers the diffuser in the gas manifold, which is required to obtain good mixing of the gas and air.

The face of the gas manifold is protected from the high flame temperatures by a refractory front plate, which is designed to withstand high temperatures. In addition, a ceramic blanket is used between the face of the manifold and the refractory to reduce the transfer of heat.



Figure B-13 Gas Manifold

Mounting Flange

A primary support for the burner is the mounting flange on the gas manifold. This provides a clamping surface to attach the burner to the vessel. A fiberglass rope gasket (3/8" dia) is used to seal the mounting flange to

the refractory front plate. The rope is wrapped around the flange several times to seal the full diameter of the flange. In addition, a ceramic blanket is used in front of the gas manifold to protect it from the internal temperatures of the furnace. The ceramic blanket should be 1" thick and wide enough to cover the face of the gas manifold.

Gas Spuds

A series of gas spuds are used to direct the gas into the air stream. These gas spuds are located around the circumference of the gas manifold. The gas spuds are arranged in a manner that gives good mixing of the air and fuel in conjunction with the diffuser.

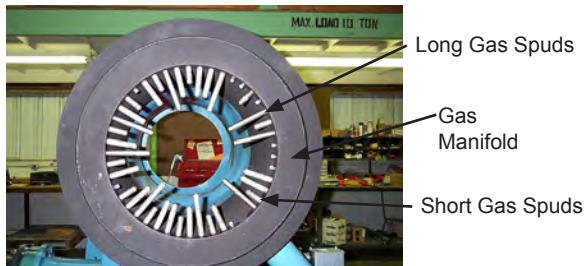

Figure B-14 Gas Spuds in Gas Manifold

Gas spud arrangement can change by fuel type, input and NOx level. In some cases, field adjustment of these spuds is required to meet different furnace configurations and field conditions.

The gas spuds are stainless steel pipe nipples that are screwed into the gas manifold. Some of the holes in the manifold are plugged with pipe plugs. "Never-Seize" must be used on the pipe threads to prevent them from seizing due to the heat at this location.

5. Oil Fuel Components

The oil system uses air or steam to atomize the oil. An air compressor is typically used for atomization, but plant air or steam can be used as an alternate. Any grade of oil can be fired from #2 through #6 oil, although high sulfur heavy oil (#4 through #6) cannot be used with FGR.

Oil Pump (Optional)

The oil pump is used to supply the oil to the nozzle at sufficient flow and pressure for the nozzle. The oil pump is provided as a separate item that must be mounted, wired and piped. The assembly consists of the pump, motor, coupling, pump-motor bracket and oil pressure regulator. The motor base mount is used to secure the assembly.

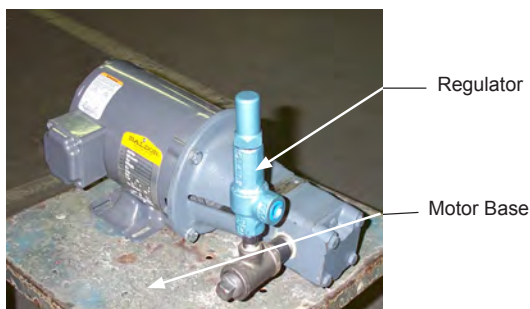

Figure B-15 Oil Pump and Regulator

Oil Pressure Regulator

An oil pressure regulator is used to maintain constant oil pressure to the burner. It is adjusted to provide the oil pressure needed at the nozzle.

Oil Supply Pressure Gauge

This indicates the oil supply pressure from the pump.

Oil Train

The oil train contains the safety shut-off valves, pressure switches and other components that may be required for the specific installation, insurance codes and local regulations and can vary greatly from burner to burner. Oil trains tend to be designed for each application and a unit specific oil train drawing is provided with each unit. Details of the actual components are provided with each burner.

Oil Safety Shutoff Valve

Each oil train has two shutoff valves. The valves can be either solenoid or motorized type and can have an optional POC (proof of closure) switch.

Low Oil Pressure Switch

This switch is set to a pressure below the expected oil pressure and will trip if the oil pressure drops below this level, shutting down the burner.

High Oil Pressure Switch

This optional switch is set to a pressure above the expected oil pressure and will trip if the oil pressure rises above this level, shutting down the burner.

Oil Heater Trim Heater (heavy oil only)

This is an electric heater that is sized to increase the oil temperature by up to 30° F and is used to provide final temperature adjustments close to the burner.

Low Oil Temp. Switch (heavy oil only)

This switch is used on residual oil burners and set to a temperature that is below the expected oil temperature. If the oil temperature drops below this temperature, it will shut down the burner. If the burner is equipped with a trim heater, this switch is located on the trim heater.

High Oil Temp. Switch (heavy oil only)

This switch is used on residual oil burners and set to a temperature that is above the expected oil temperature. If the oil temperature rises above this temperature, it will shut down the burner.

Manual Ball Valve

A manual valve is provided in the oil line to perform testing of the safety controls as part of the normal startup procedures.

Oil Flow Control Valve

The oil flow control valve regulates the flow of oil to the nozzle. The oil flow control valve modulates with the air damper to provide different input rates. On a single point positioning system (linkage), it is connected to the jackshaft and uses a fuel cam to make fine adjustments to fuel flow. With a parallel positioning system (linkageless), an

actuator is connected to the oil control valve and modulated by electronic control to the desired position.

Oil Nozzle

Several different types of oil nozzles may be used depending on the type of oil system, burner size, turndown and application. They all share a common purpose of atomizing the oil into small droplets so that they will easily and quickly burn. The oil nozzles use either air or steam to atomize the oil. All of the nozzles are mounted to the end of the oil gun and are inserted into the support tube. The position of the nozzle can be adjusted by moving the gun in the tube. The oil nozzles and gun have a “Top and Bottom” position that is critical for correct operation. The end of the oil gun is marked with the word “TOP”.

Figure B-16 shows the components of typical air atomizing nozzles. The nozzle tip and swirler are lapped together to form a perfect fit and can only be used together as a matched set. Other air atomizing nozzles may have slightly different construction.

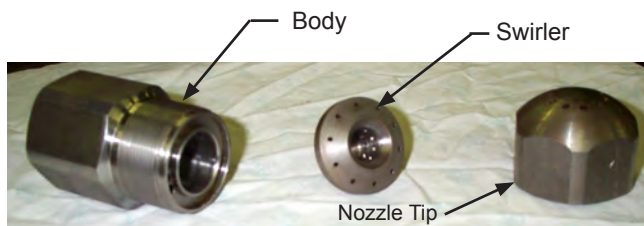

Figure B-16 Typical Large Air Atomizing Oil Nozzle

Oil Gun

The oil gun consists of the oil nozzle and pipe connections for the nozzle. The oil gun slides into the guide tube. Two blocks are used to keep the gun centered in the guide tube and lock the gun to the end of the guide tube.

The gun assembly must be mounted in the correct (vertical) position, with the word “TOP” located on top of the gun assembly. This will allow for even oil distribution and prevent oil dripping out of the gun and lines after shutoff.

Nozzle Oil Pressure Gauge

This gauge indicates the oil pressure at the oil nozzle. This reading is important in determining proper operation of the nozzle for atomization at any given firing rate. There is a wide range of possible pressures, but typically it is in the range of 15 to 60 psi.

Nozzle Atomizing Air Pressure Gauge

This indicates the atomizing air (or steam) pressure at the nozzle. This reading is important in determining proper operation of the nozzle for atomizing the oil. The pressure can vary widely depending on the nozzle and rate, but typically it will be in the range of 15 psi at low fire to as high as 55 psi at high fire.

Air Compressor

The air compressor, if used, provides air to the oil nozzle to atomize the oil. The compressor assembly includes the compressor motor, relief valve and flexible connection to isolate the vibration of the air compressor. The large air

compressor (Figure B-17) is equipped with rubber mounts that must be used when mounting the compressor to a base.

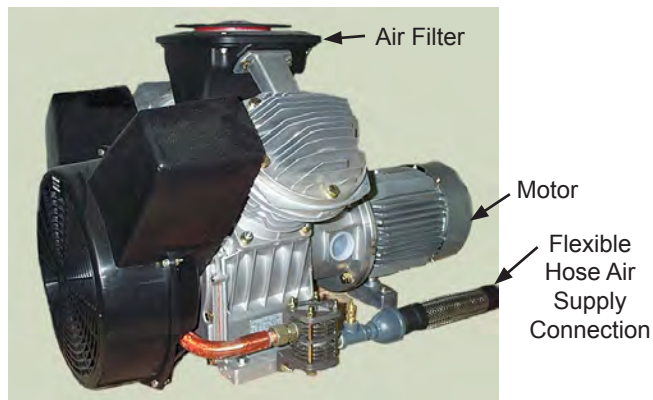

Figure B-17 Large Air Compressor

Atomizing Media Control

The atomizing media can be controlled in different ways. House air and steam are controlled by a modulating flow control valve. If an air compressor is used, the flow will be controlled by bleeding some air off, with either a fixed valve or modulating valve. An air muffler is provided to reduce the noise from bleeding off air.

6. Flue Gas Recirculation (FGR)

The flue gas recirculation components in this section only apply to the HDRSX model that uses recirculated flue gas to reduce the NOx emissions.

FGR Control Valve

The FGR control valve controls the flow of recirculated flue gas. The valve is connected to the FGR inlet tube at the combustion air inlet. The FGR inlet tube is in a negative pressure zone, which creates the pressure differential for FGR flow.

The FGR control valve modulates in conjunction with the fuel and air valves to provide different input rates. On a single point positioning system (linkage), it is connected to the jackshaft. With a parallel positioning system (linkageless), an actuator is connected to the FGR control valve and modulated by electronic control to the desired position.

FGR Shutoff Valve

Single point positioning systems (linkage) require a separate FGR shut-off valve that prevents flow during the purge cycle. The valve is driven by a motor to close the FGR line during the purge cycle. Parallel positioning systems will modulate the control valve shut during purge and do not require a shut-off valve.

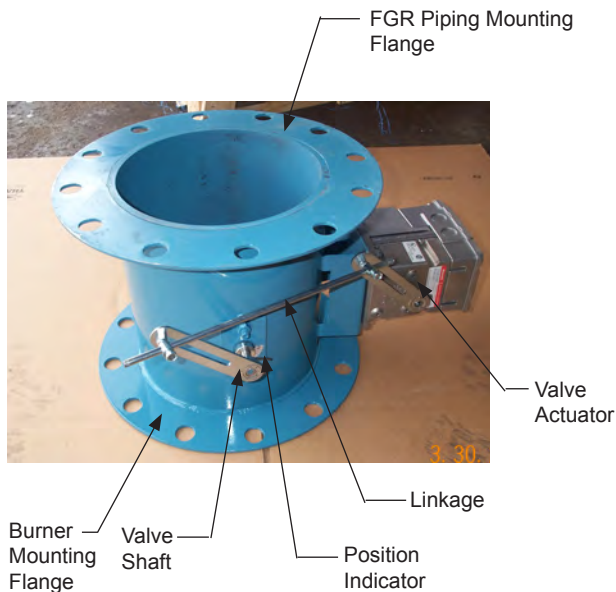

Figure B-18 FGR Shutoff Valve

The shutoff valve should be installed in the FGR duct close to the boiler connection. The valve stem should be horizontal, to prevent condensate from building in the shaft bore, causing it to seize.

When firing oil, this valve may be closed or it may be partially open to provide some FGR. If the valve is intended to be partly open, there will be a potentiometer in the control panel to adjust the position of this valve.

FGR Duct

The FGR duct provides the connection between the boiler outlet and the control or shut-off valve. The design of this duct is very important for proper operation and to prevent maintenance problems (see Section C).

7. Fuel-Air-Ratio Controls

The burner may be equipped with single point positioning (linkage), multiple setting modulating motor or parallel positioning system (linkageless). All of these systems provide the basic fuel-air-ratio control required for good combustion, however they can provide different features and setup capabilities.

Modulating Control

The burner modulates to match the energy requirements of the load. It does this by using a sensor that measures the pressure or temperature of the system and a matching sensor in the modulating motor that moves to match the readings of the sensor.

In some optional systems, a similar process is used with an external control that provides a signal to the motor to go to a certain rate. These systems may include multiple burner sequencing, outside temperature compensation and numerous other control strategies.

Single Point Positioning (Linkage)

Single point positioning systems use a single modulating motor to vary the fuel input, air flow and other flow changes like FGR and atomizing air flow. Linkage is used

to connect these flow control elements together to provide a unified fuel-air-ratio control system. Other elements in this system would typically include a jackshaft, fuel cam and modulating motor.

Jackshaft

The jackshaft is a shaft that is used to tie the fuel, air and FGR valves together with linkage, to provide a uniform change in the flow as the burner modulates. A modulating motor is used to drive the jackshaft, driven by the requirement for heat in the system and as allowed to operate by the flame safeguard.

The jackshaft is a 3/4" shaft that rotates and is mounted in bearing supports. This provides a common means of modulating all of the valves from a single drive mechanism. The length can vary to meet overall dimensions and individual drive arms are used to connect to each valve.

Fuel Cam

A fuel cam is a mechanical linkage that allows for small fuel rate changes without changing the linkage setting. It can simplify the fuel-air-ratio adjustments during the burner setup (Figure B-4 and E-7).

Modulating Motor

The jackshaft is driven by a modulating motor that rotates 90° to modulate the burner input from minimum rate to maximum rate. Linkage is used to connect the modulating motor to the jackshaft and the fuel cams along with connecting the fuel, air and FGR control valves to the jackshaft.

The standard modulating motor has two internal proving switches. One switch, the Low Fire switch, proves the low fire position where the burner will light. This is also the position the modulating motor will travel to when the burner shuts down. The second switch, the High Fire Purge switch, proves the high fire purge position during pre-purge.

Multiple Setting Modulating Motor

In some burner configurations, there are different ideal settings for oil and gas firing, especially when higher turndown is desired. This can be accommodated with an optional modulating motor that has different low fire and high fire positions for gas vs oil.

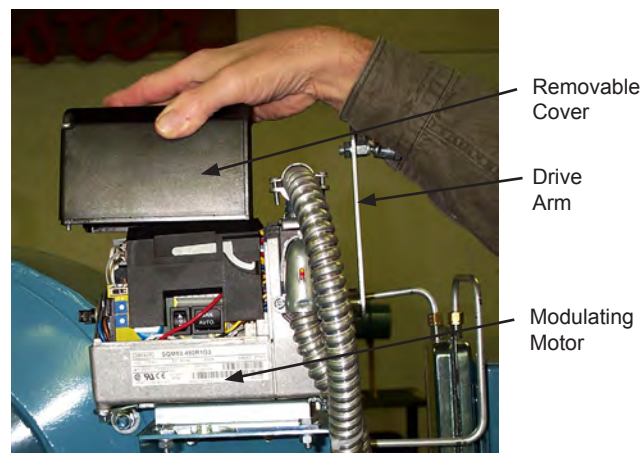

Figure B-19 Siemens Mod Motor Adjustments

This optional modulating motor uses four to eight internal switches. One switch is used to prove the high fire purge position during pre-purge. A second switch is used to prove the fully closed position. This is the position of the motor when the burner is off. A third switch is used to prove the ignition position. This is the point at which the burner will light. A fourth switch is the low fire position. This is the position of the lowest firing rate of the burner. It can be different from the ignition position, if desired. If the burner is a combination gas-oil burner, two additional switches may be used. These switches do the same function as the third and fourth switches already listed, but can be set up to allow for different ignition and low fire positions for gas and oil operation. There is also a 7th and 8th switch that can be used to accommodate two different high fire settings. See the burner wiring diagram to determine the switch numbers and functions.

Oil Limiting Potentiometer (Linkage System Only)

The fan is sized for air at rated capacity plus the quantity of FGR required for gas NOx emissions. When firing oil, the FGR rate is usually reduced, providing a larger fan capacity than desired. To prevent the burner from over firing on oil, a limiting potentiometer is used to limit the oil rate. In this mode, the modulating motor is restricted in its travel to something under 90°.

This potentiometer is located in the control panel and is adjusted at startup to provide the correct oil firing rate.

Parallel Positioning System (Linkageless)

The Posi-Control system is a parallel positioning system (linkageless) that uses individual actuators for each control valve and a computer controller that directs each actuator to provide the input change from minimum to maximum capacity. The control provides more flexibility in setting each fuel rate (Figures B-1 and B-2).

8. Electrical Controls

Control Panel

The control panel (Figure B-5) contains the flame safeguard control, relays, terminal strips for electrical connections and other components required for the control of the unit. Other components may be included for the operation of the boiler, for example, a low water cutout relay.

Flame Safeguard

The flame safeguard (Figure B-5) provides operational control and safety sequencing for the burner. Safety limits are tied to the unit and it controls the operation of the fuel valves. The flame scanner is part of this control and can detect a flame failure causing a safety shutdown. There are several different flame safeguard models available with different features and cost levels. They can provide fault annunciation and communications with other controls. The details of the control used in the burner are supplied with the unit.

On-Off Switch

This switch is used to start and stop the burner by opening or closing the limit circuit to the flame safeguard control.

Manual-Auto Switch and Potentiometer

The Man-Auto switch is used to select what signal source is used for modulation control of the burner. With the switch in the “Man” position, the burner firing rate is determined by the position of the manual potentiometer. With the switch in the “Auto” position, the burner firing rate is determined by the signal from the boiler modulating controller. When in the “Auto” position, the manual potentiometer can limit the firing rate of the burner from anywhere between low fire and high fire. The modulating motor will always drive open and closed during pre-purge, regardless of the position of the Man-Auto switch and potentiometer.

Manual Potentiometer Rate Control

The manual potentiometer is used to manually position the firing rate when the burner “Auto-Manual” switch is in the “Manual” position. This is used to setup and check the burner. When in the “Automatic” position, this potentiometer acts as a firing rate limiting potentiometer. Placing it at the low fire position will prevent the burner from modulating above low fire. For normal automatic operation, this must be positioned at the full rate (clockwise) position.

Fuel Transfer Switch

This switch selects the proper fuel for firing. It has a center off position that prevents moving the switch from one position to the other, without momentarily stopping in the center off position.

Power On light

Indicates power is applied to the control panel.

Call For Heat light

Indicates the burner On-Off switch is closed and the boiler limits are closed.

Fuel On light

Indicates the main fuel valve circuit has been energized.

Alarm light

Indicates the flame safeguard control is in a safety shutdown and lockout condition. The flame safeguard control reset button must be pressed before the burner can operate again.

On some burners the Alarm light may also be used to indicate other failure conditions such as low water, high limit, etc. See the burner wiring diagram for details of what other controls may be wired to the Alarm light.

Control Transformer (Optional)

The control circuit transformer is used to reduce the main power input to 115 VAC for the control circuit. If this electrical supply could be provided as a separate input, this transformer would not be required. The transformer has two fuses located on the transformer box.

Alarm Bell

The alarm bell (or buzzer) provides an audible noise if the burner were to lock out due to an alarm condition.

Control Relays

Relays are provided to support electrical options. The number and type of relays will vary with the equipment. These relays will be indicated on both the wiring diagram and material list.

Motor Starters

At least one motor starter, for the combustion air fan, will be included in each control panel. If other motors are used, for an oil pump or air compressor, these starters will also be located in the control panel.

Junction Box

The junction box contains the electrical connections that are required between the burner and control panel.

C. Installation

1. General Considerations
2. Refractory Frontplate
3. Burner Mounting
4. Gas Piping
5. General Oil Piping
6. Air Atomized #2 oil
7. Heavy Oil
8. Gas Pilot
9. FGR System
10. Draft and Stacks
11. Electrical

This section covers the installation procedures for each of the standard systems offered on the HDRS (HDRS-RF and HDRSX-RF) burner line. Your specific burner will not have each of these systems and may be supplied to you as an installed system. If you receive the burner as part of a new boiler for example, the burner may be installed in the vessel with much of the piping already done. For this reason, a complete review of the installation is required to determine which tasks are complete and which need to be done.

THE INSTALLATION OF THE EQUIPMENT SHALL BE IN ACCORDANCE WITH THE REGULATION OF AUTHORITIES HAVING JURISDICTION, INCLUDING THE NATIONAL ELECTRICAL CODE, INSURANCE REGULATIONS, CSA STANDARDS 139 AND 140, THE CANADIAN NATIONAL ELECTRIC CODE AND ALL LOCAL CODES.

The equipment shall be installed in accordance with the state and local requirements and in Canada, in accordance with Provincial Installation Requirements, or in their absence, the CGA B149.1 and B149.2 codes shall prevail. Authorities having jurisdiction should be consulted before installations are made.

NOTE TO INSTALLER: The main power disconnect for this equipment must be conspicuously labeled and placed within sight of the operating system and equipped with lockout provisions.

1. General Considerations

In the initial planning of the installation, several items must be covered:

a. Prior to starting the installation, all the technical literature should be collected and reviewed to identify requirements. As a minimum, these should include the Installation and Operating Manuals for the burner and vessel, the wiring diagrams, the fuel schematics and technical literature on supplied controls.

b. A general overview of the equipment should be made prior to the installation. Check the location of access doors and insure that they will be able to function properly when all equipment is installed. The burner and control panel should have sufficient clearance for the operator to monitor, inspect and perform maintenance. A minimum clearance of 36 inches all around the burner should be provided for maintenance. The burner drawer and oil gun is pulled out from the front of the burner and there needs to be sufficient space for this activity.

c. A source of combustion air must be provided for the burner. Local codes often determine minimum require-

ments, and these must be followed. In absence of other codes, the following can be used.

Webster recommends two air sources be provided, one located high and one low. Each air source must be at least 1 ft². If there are multiple burners, the area must consider all burner requirements. Exhaust fans are not recommended as they create additional air flow requirements that must be included in the area calculation.

The quantity of air required for combustion and ventilation is 10 cfm/BHP. The maximum air velocity is 250 ft/min from the floor to 7 feet high, and 500 ft/min above 7 feet high. Outdoor louvers may restrict the open area, and if the exact restriction is unknown, a restriction of 20% can be used. Add 3.5% to the area for each 1000 ft above sea level. The calculations are,

$$\text{Total air required (cfm)} = \text{BHP} \times 10$$

$$\text{Open area} = \text{cfm} / \text{velocity}$$

$$\text{Louvered area} = \text{open area} \times 1.2 \text{ (or actual)}$$

$$\text{Area of opening} = \text{louvered area} / 2$$

For example, with duct located under 6' high for a 500 HP boiler, what would their area need to be? The total air is (500 BHP x 10 cfm/BHP) = 5000 cfm. The maximum velocity is 250 ft/min, so the open area must be = (5000 cfm / 250 ft/min) = 20 ft². Since these opening will have louvers, the actual openings must be = (20 ft² x 1.2) = 24 ft². There will be two opening, so each will be = (24 ft² / 2) = 12 ft².

The location of the combustion air source must not create a condition where the burner or vessel comes in contact with very cold air (under 40°F) or causes large fluctuations in combustion air temperature. Cold air can cause condensation below 40°F in a standard burner and below 50°F when equipped with FGR.

There should be no large variations in combustion air temperature supplied to the burner. The burner can be adjusted to handle temperature variations of 30°F, but may not be able to handle temperature swings of 50°F without combustion deterioration. In conditions where this can occur, some conditioning of the combustion air must be done by location, baffling or pre-heating of the air. Seasonal tune-ups can also help cover the larger temperature swings.

d. There are several people that should be notified before starting, including the owners representative, the mechanical contractor, the electrical contractor, the service organization and the boiler manufacturer.

e. DO NOT USE TEFLON TAPE or compounds with Teflon content as an oil or gas pipe sealant. Teflon can cause

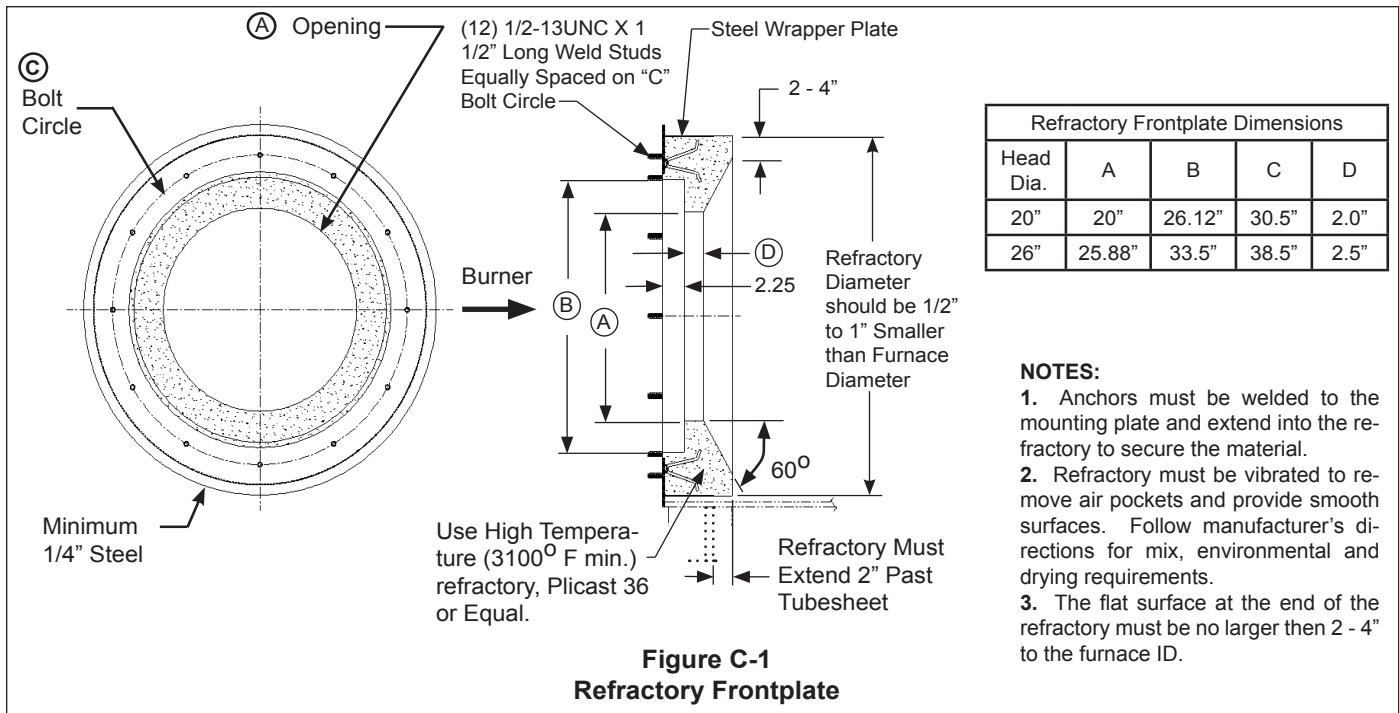

valves to fail creating a safety hazard. Warranties are nullified and liability rests solely with installer when evidence of Teflon is found.

f. Installer must clearly identify the main electrical power disconnect and the manual shutoff valve on the gas supply drop line to the burner.

2. Refractory Frontplate

The refractory front plate is used to adapt the burner to the vessel. While the specific dimensions will vary with different vessel and burner configurations, all will be similar in shape to that shown in Figure C-1. A mounting flange on the frontplate is used to clamp the frontplate to the vessel. Bolts on the frontplate are used to clamp the burner to the frontplate. High temperature fiberglass rope gaskets are used to seal each connection.

A rope gasket is applied to full surface of the frontplate mounting flange (it must cover the full face of the flange) to seal the refractory front plate to the vessel (a spray adhesive can be used to hold the gasket in place temporarily).



Figure C-2 Ceramic Blanket and Rope Gasket

The refractory frontplate is inserted into the furnace and clamped to the end of the furnace. The refractory must be centered in the furnace, so that the gap between the refractory and furnace is uniform. Clamp the frontplate to the furnace with uniform tension on the bolts, starting with a low torque for all bolts and then repeating with higher torque levels until tight.

Pack the gap between the refractory and furnace with ceramic blanket insulation (or ceramic rope) for at least 4 inches from the end of the refractory (Figure C-3). This can be accomplished by reaching in from the center hole, and placing the insulation between the refractory and furnace, then pushing it in with a block.

3. Burner Mounting

A rope gasket is applied to the burner mounting flange, completely covering the flange (the 3/8" fiberglass gasket is provided with the burner). A ceramic insulation is placed on the end of the burner, as shown in Figure C-2. A spray adhesive can be used to hold these in place prior to installation.

The burner is then inserted into the frontplate, centered evenly (the 2 inch recess will center the burner) and clamped into position. Clamp the burner to the frontplate with uniform tension on the bolts, starting with a low torque for all bolts and then repeating with higher torque levels until tight.

The burner should be checked for level and must be perpendicular to the vessel. If the burner is not level or perpendicular, loosen the mounting clamps, reposition the burner and retighten. This will properly align the burner flame with the furnace and allow the proper flow of liquid. Oil combustion will not work properly if not level.

The burner is equipped with mounting supports to secure it to the floor. These are pipe coupling attached to the

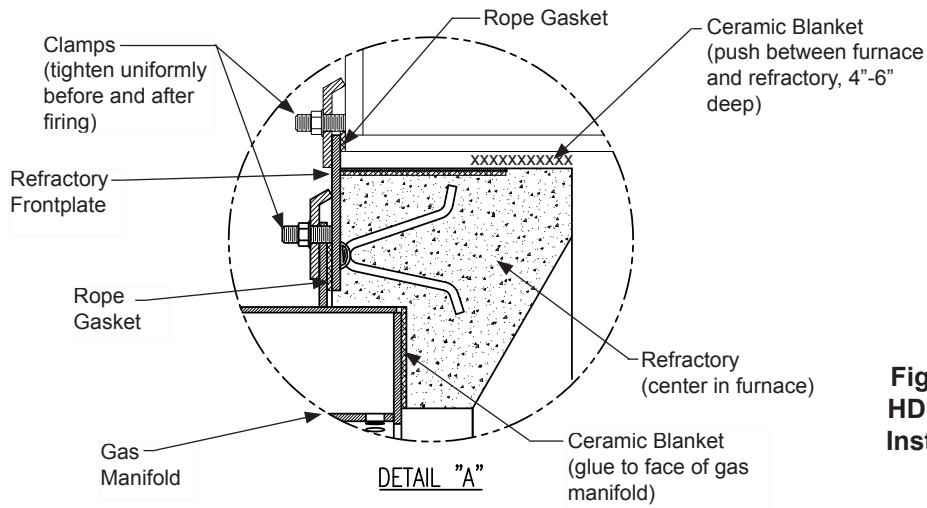
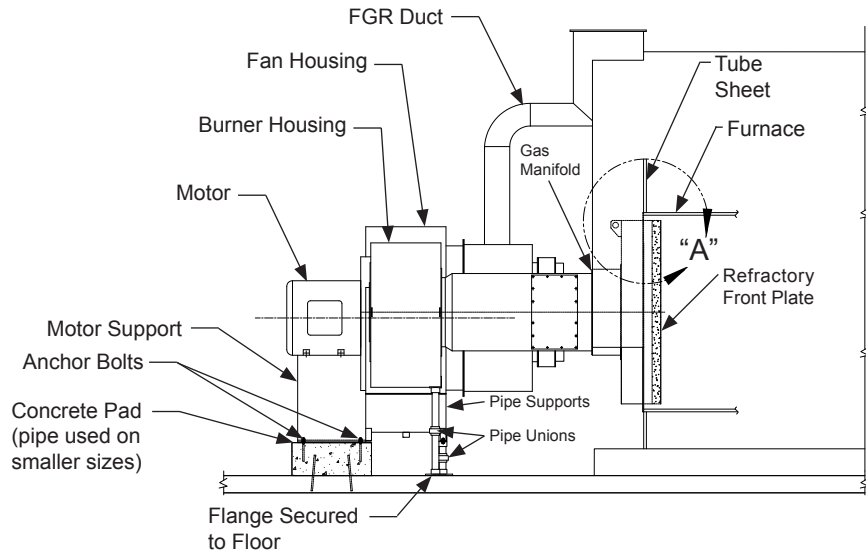

**Figure C-3
HDRSX-RF
Installation**

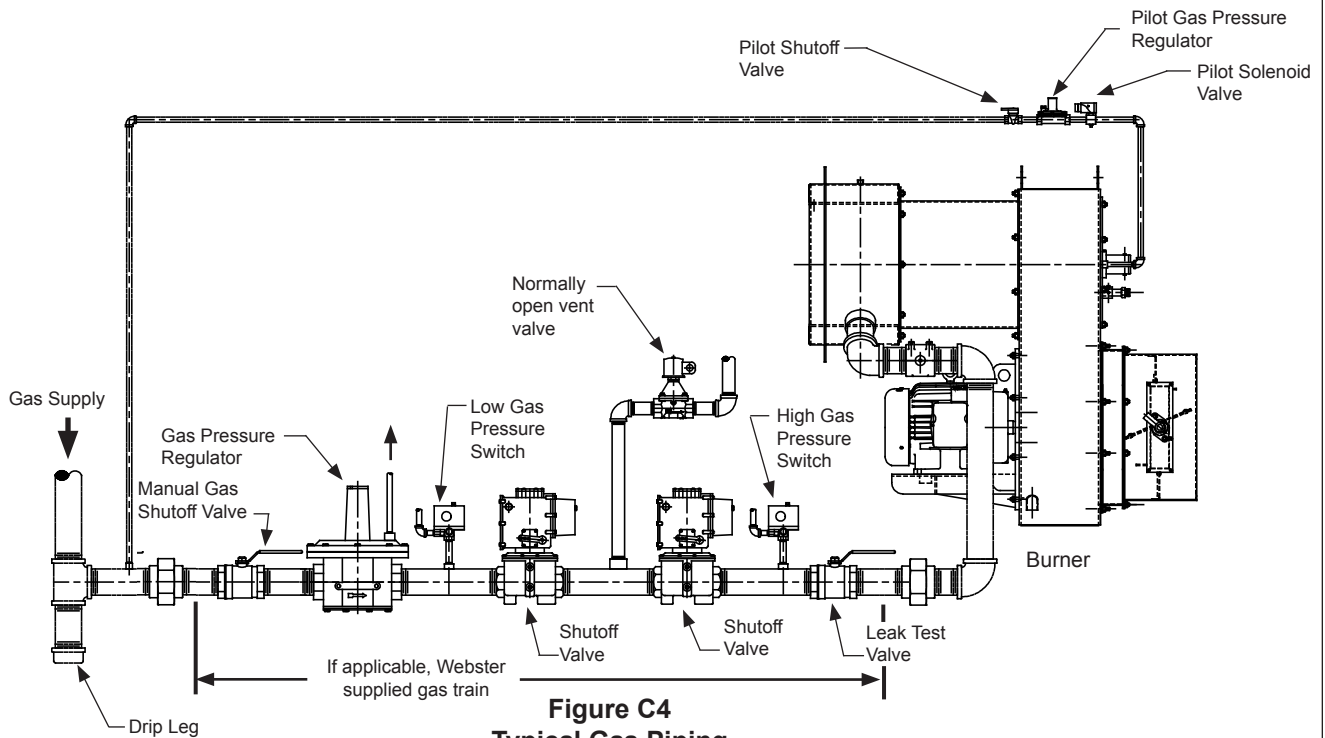

**Figure C4
Typical Gas Piping**

burner at the windbox and motor mounting plate. On larger units, the motor mounting will have a box structure under it to reduce the chance for vibrations. To secure the burner to the floor, pipe sections are installed to these couplings and a flange mount is secured to the floor, as shown in Figure C-3.

4. Gas Piping

WARNING
DO NOT USE TEFLON TAPE OR COMPOUNDS CONTAINING TEFLON. THIS COULD DAMAGE THE VALVES CREATING AN UNSAFE OPERATION

NOTE TO INSTALLER: The manual shutoff valve on the gas supply drop line to the burner must be conspicuously labeled.

Figure C-4 shows a typical gas piping schematic, although some components can vary based on size, insurance and other requirements. Consult the job specific gas train piping schematic (provided with the burner if train is supplied by Webster), along with a detailed list of components for specific details. This must be followed to properly locate the components in the gas train.

The gas piping must comply with all local and state codes and must be in accordance with the local gas company and insurance requirements.

If the gas train has not been factory assembled, the components should be assembled as indicated on the gas piping schematic furnished with the burner. The section between the two manual shutoff valves is mounted securely to the base rail on the side of the vessel. A drip leg should be provided upstream of the first manual valve to collect any moisture or contaminants.

Some general considerations for this installation are:

- a. The piping to the burner must be sized to provide gas at the pressure and volume indicated on the order.
- b. The gas piping should be installed according to local regulations and any applicable insurance requirements.
- c. The gas pressure regulator usually requires a minimum straight length of pipe leading into and from the valve for proper operation. Also some regulating valves require a downstream pressure tap that must also be located at a certain dimension from the valve. These details are provided in the job specific details provided with the burner.
- d. The piping between the train and burner must be done in a manner that will minimize the pressure drop. The pipe size should be the larger of the two connection points (on the train or the burner connection) and must use a minimum amount of elbows.
- e. The gas piping should be cleaned to remove filings and other debris common in the construction process.
- f. The piping should be pressure tested with inert gas at two times normal operating pressure before use. Check main and pilot regulators for maximum inlet allowable pressure.

5. General Oil Piping

WARNING
DO NOT USE TEFLON TAPE OR COMPOUNDS CONTAINING TEFLON. THIS COULD DAMAGE THE VALVES CREATING AN UNSAFE OPERATION.

The amount of oil piping required in the field will depend on the type of system and how the burner was purchased. If the burner was factory mounted to the boiler, much of the installation work may already be complete. Units with heavy oil have more complexity built into them and will require more installation effort. The items identified in this manual assume that none of the installation work has been done by others.

The oil piping must be constructed to provide the flow and maintain the pressure required for proper system operation. Refer to the previous section for details on each of the different types of oil systems and how they operate.

Some of the actions required for successful piping systems are:

- a. Oil storage tanks and piping must conform to The National Fire Protection Association "Standard for the Installation of Oil Burning Equipment NFPA-31", local ordinances and EPA underground storage tank requirements.
- b. Oil lines shall be substantially supported and protected against physical damage. Buried lines shall also be protected against corrosion.
- c. After installation and before covering, buried lines should be pressure tested for leakage.
- d. Cast iron fittings should not be used.
- e. Aluminum tubing should not be used.
- f. Proper allowance should be made for expansion and contraction, jarring, vibration and tank settling.
- g. Always run full size lines.
- h. Suction and return lines shall be as short as possible.
- i. The oil lines must be cleaned to remove water, rust and foreign matter. A common method of cleaning the oil piping is to temporarily install a short copper tube to the pump inlet, feeding the pump oil from a bucket. The gauge must be removed and the tapping plugged. The pump is run for a short time by manually engaging the motor starter by pushing it with a piece of wood. If flow does not establish within 2 minutes of engaging the pump, shut the pump off and run through the priming procedure again.
- j. The standard oil pumps supplied on the HDRS are Viking Model SG operating at 1750 rpm. These pumps can provide suction (vacuum) of 10 inch of Hg when used to pull from a tank. If a transfer pump is used, the maximum inlet pressure that the pump can tolerate is 15 PSIG, although most regulations require a maximum transfer loop pressure of 3 PSIG.
- k. A strainer is required to protect the pump, valves and oil nozzle. This strainer is not part of the standard equipment supplied by Webster, but is intended to be supplied and installed by others. The strainer should have

a maximum filter opening of 0.027" for #2 oil and 0.056" for #4-6 oil and sized to handle the full flow rate of the pump. The strainer must also handle the temperature (Figure D-3) and pressure (maximum 25" vacuum). Retain and follow the strainer instructions supplied by the manufacturer. It is essential that these instructions be followed to insure proper filtration to protect the pump, valves and nozzle.

l. In Canada, refer to CSA Standard B139, "Installation Code for Oil Burning Equipment" for recommended installation procedures.

m. The oil lines and most valves are sized to handle the full pump capacity, as shown in figure C-5. The pumps are selected for a capacity of at least 1.5 times the maximum nozzle rate. If pumps are used with substantially higher flow rates, these selections may not function correctly. This is especially critical for the pressure atomized system where the metering valve is sized for the pump flow.

The selection of the oil pipe line size is critical for proper operation of the system.

To determine the equivalent length of the oil piping, use the straight length of piping and add the equivalent length of straight pipe given for each fitting.

CAUTION
PUMP FAILURES CAUSED BY FOREIGN MATTER IN THE OIL LINES WILL NOT BE COVERED BY WARRANTY

6. Air Atomized #2 Oil

The standard HDRS air atomized burner equipped for light oil may not include the optional oil pump (Figure C-5). Oil is to be delivered to the burner at a constant 125 PSIG and with a flow capacity that is at least 50%

higher than the rated nozzle capacity. The regulator must be capable of adjusting this pressure down to a potentially lower valve of 75 psi, or any intermediate pressure that may be required for proper operation of the burner. See section A for ratings.

The general arrangement for this system is shown in Figure D-4. A supply and return line connection are required, along with the components indicated. The lines must be sized correctly to provide the required flow with minimal pressure drop. The pressure in the return line should not exceed 3 PSIG.

The oil supply and return lines must be piped to the burner, with the components installed as shown in the schematic. The oil pressure regulator must be located close to the burner to provide a constant oil supply pressure.

7. Heavy Oil

The standard HDRS burner equipped for heavy oil will include a trim heater and controls, but not the pump or primary heater. Oil is to be delivered to the burner at 125 PSIG and at a temperature that is within 30°F of the final oil temperature. The pressure regulating valve must be capable of controlling the pressure anywhere in the range of 75 to 125 psi, as required for proper burner operation.

The primary oil heater (provided by others) may be required to reach the temperatures needed for good atomization. This can be accomplished with a heat exchanger that uses steam, hot water or electrical energy, or it could be done by simply heating the oil tank. In either case, the oil must be provided to the burner at a temperature that is within 30°F of the required atomization temperature (Figure D-3).

The general arrangement for this system is shown in Figure D-5. A supply and return line connection are required, along with the components indicated. The lines must be sized correctly to provide the required flow with minimal pressure

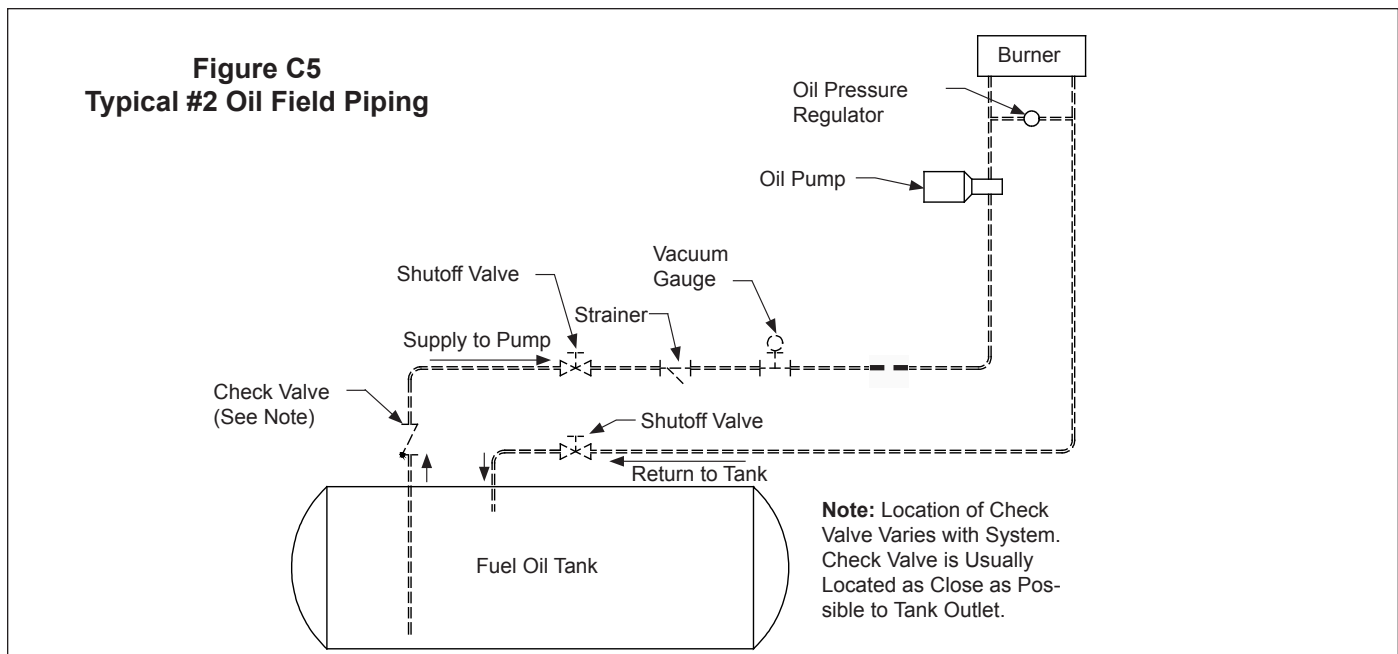

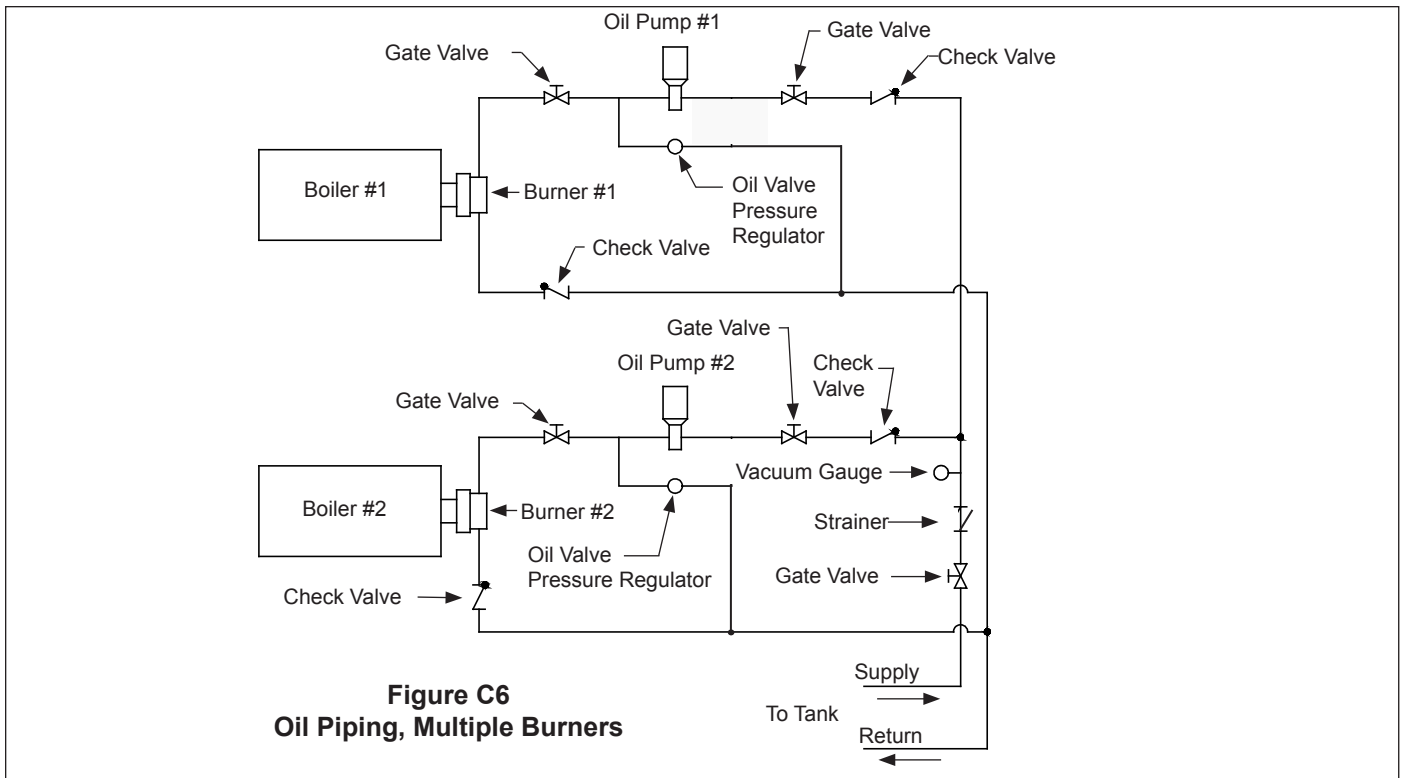

Figure C6
Oil Piping, Multiple Burners

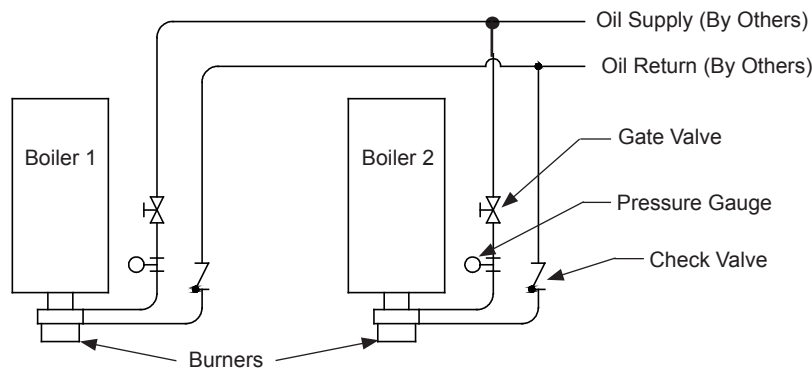

Figure C-7
Oil Schematic, Multiple Burners with Remote Oil Pumps

Note: No Return Line Required for #2 Oil Air Atomized

drop. The pressure in the return line should not exceed 3 PSIG.

The oil supply and return lines must be piped to the burner, with the components installed as shown in the schematic. The motor base of the oil pump and air compressor should be bolted securely to the floor or some rigid base.

8. Gas Pilot

The typical piping arrangement for the gas pilot is shown in Figure C-4. The supply is connected upstream of the first manual gas valve. This piping should be done using 1 inch schedule 40 piping.

9. FGR Duct System

If the burner is equipped with Induced Flue Gas Recirculation (IFGR), it will require a duct connection between the stack outlet of the boiler and the air inlet of the burner. FGR is used to reduce NOx emissions. There can be different levels of NOx emissions that require different quantities of

flue gas and different FGR duct and valve sizes. Proper sizing and installation of the FGR duct must be done to provide the required emission control and burner performance.

The FGR control valve is already installed on the burner and the duct will connect to this point. A flange is supplied on the burner that the pipe can be welded to. Depending on the duct size required, a pipe reducer may be required to match the control valve to the duct. The control valve is usually a smaller pipe size. The FGR shutoff valve may also require a pipe reducer, depending on the duct size. Two flanges are provided on the shutoff valve to weld to the inlet and outlet pipe.

If the FGR duct is to be installed in the field, the following procedures should be used to determine the best arrangement. The process uses a "Trial and Error" sequence to evaluate different possible duct arrangements.

FIGURE C-8 Pressure Drop per 100 feet of Duct (in wc)									
BHP	Max Inlet Pressure	6"	8"	10"	12"	14"	16"	18"	20"
Pressure drop for 60ppm NOx - Natural Gas Firing									
1300	2.00	6.3	1.4	0.4	0.2				
1400	2.00	7.3	1.6	0.5	0.2				
1500	2.00	8.4	1.8	0.5	0.2				
1600	2.00		2.1	0.6	0.3				
1700	2.00		2.4	0.7	0.3				
1800	2.50		2.6	0.8	0.3				
2000	2.50		3.3	1.0	0.4				
2200	2.50		3.9	1.2	0.5				
2300	2.50		4.3	1.3	0.6	0.3			
2400	2.50		4.7	1.4	0.6	0.3			
2500	2.50		5.1	1.5	0.7	0.3			
2600	2.50		5.5	1.6	0.7	0.3			
Pressure drop for 30ppm NOx - Natural Gas Firing									
BHP	Max Inlet Pressure	6"	8"	10"	12"	14"	16"	18"	20"
1300	2.50			5.2	2.3	1.0	0.5	0.3	
1400	2.50			6.0	2.6	1.2	0.6	0.4	
1500	2.50			6.9	3.0	1.4	0.7	0.4	
1600	2.50			7.9	3.4	1.6	0.8	0.5	
1700	2.50			8.9	3.9	1.8	0.9	0.6	0.4
1800	2.50				4.4	2.0	1.0	0.6	0.4
2000	2.50				5.4	2.5	1.3	0.8	0.5
2200	2.50				6.5	3.0	1.5	1.0	0.6
2300	2.50				7.1	3.3	1.7	1.0	0.7
2400	2.50				7.7	3.6	1.8	1.1	0.7
2500	2.50				8.4	3.9	2.0	1.2	0.8
2600	2.50				9.1	4.2	2.1	1.3	0.9
Pressure drop for 20ppm NOx - Natural Gas Firing									
BHP	Max Inlet Pressure	6"	8"	10"	12"	14"	16"	18"	20"
1300	2.50				5.5	2.5	1.3	0.8	0.5
1400	2.50				6.4	2.92	1.5	0.9	0.6
1500	2.50				7.4	3.4	1.7	1.1	0.7
1600	2.50				8.4	3.8	2.0	1.2	0.8
1700	2.50					4.3	2.2	1.4	0.9
1800	2.50					4.9	2.5	1.6	1.0
2000	2.50					6.0	3.1	1.9	1.3
2200	2.50					7.3	3.7	2.3	1.5
2300	2.50					8.0	4.1	2.5	1.7
2400	2.50					8.7	4.4	2.8	1.8
2500	2.50					9.4	4.8	3.0	2.0
2600	2.50					10.2	5.2	3.2	2.1
Equivalent Length of Fittings (ft)									
Close 90° Elbow	13	17	22	26	30	35	42	46	
Long Radius 90° Elb	10	14	17	20	23	27	29	32	
"T" side 90°	32	42	52	61	71	81	96	107	

- Put together a duct arrangement based on a estimated duct size.
- Determine the equivalent total pipe length based on the arrangement and fittings used.
- Calculate the actual pressure drop in the duct using the value in Figure C-8 for the drop per 100' of pipe for the boiler HP and NOx level.
- If this pressure drop is higher than the allowed drop, select a larger duct size or fittings that have a lower equivalent length and repeat the above steps.
- If the calculated pressure drop is less than the maximum drop, that arrangement can be used.

Each fitting used in the duct has an equivalent straight pipe length, which is used to determine the total equivalent length. By adding up all of the equivalent lengths (including the length when multiple fitting are used) and all of the straight pipe lengths, the total equivalent length can be determined. This number is used to determine the pressure drop.

Figure C-8 provides pressure drop information used in sizing the FGR duct. The maximum FGR duct pressure drop is given for different inputs and NOx levels. The duct must be sized to be under this pressure. For a specific duct design, the equivalent length is used with the pressure drop per 100 feet of duct (selected from the chart, for the burner input and NOx level). The total pressure drop is:

$$\text{Press. drop} = (\text{drop per 100 feet}) \times (\text{equivalent length})/100$$

This is the pressure drop expected from the duct that was selected. If the pressure drop is higher than the maximum allowed drop, the duct must be modified to reduce the pressure drop. This can be done by reducing the total length, using fittings with lower pressure drops or using larger pipe sizes. The pressure drop from the FGR control valve and shutoff valve (if required) do not need to be included in this evaluation.

For example, consider the arrangement shown in Figure C-9. There will be three long radius 90 degree elbows and 42 feet of straight pipe. If 12" pipe is used, then the total equivalent length will be:

$$E \text{ Length} = (3 \times 20) + 42 = 102 \text{ E ft.}$$

If this is a 600 BHP 30 ppm system, then the maximum duct pressure drop is 2". The calculated drop is:

$$\text{Pressure drop} = 102 \text{ ft.} \times (4.4"/100 \text{ ft}) = 4.5"$$

which is higher than allowed (max is 2.5"). Adjusting the pipe to 14" gives a new equivalent length of:

$$E \text{ Length} = (3 \times 23) + 42 = 111 \text{ E ft.}$$

$$\text{New pressure drop} = 111 \times (2.0"/100 \text{ ft.}) = 2.22"$$

This pressure drop is less than the 2.5" max.

The design of the FGR duct must include the following considerations,

- Normally the duct would connect to the stack as shown in Figure C-9, with a 45 degree cut facing the flue gas flow and with the center of the cut centered in the stack.

The duct could be made to the smoke box, but must still be located with the same 45 degree cut facing the flue gas flow stream and with the center of the cut in the center of the stream.

b. The duct should be routed in a manner that has the minimum number of elbows and provides for the normal expansion and contraction of the piping. Long duct runs can change length by over 1" and can put an extreme load on the connecting points that could cause component failures. The design must include offsets that will allow for the required movement of the piping without undue force on the burner or stack.

c. Duct expansion and contraction can be managed by using two relatively long duct runs that are 90 degrees apposed to each other, similar to that shown in Figure C9. A small movement in the angle between these two legs will provide the space needed to absorb the expansion and contraction. The ends of the FGR duct must be securely attached to allow this to work properly, and prevent high loads from being applied to the burner or stack.

d. A condensation drip leg must be provided upstream of the FGR control valve and the FGR shutoff valve (if used). There must be sufficient condensate drip legs and catch space (volume of drip legs) to prevent the condensation from flowing through the control valves and into the fan. In cases of heavy condensation, a condensate drip leg may be required on the bottom of the housing, to remove condensate.

e. Determine the duct size, as indicated above. Remember that changing the fitting type and number of elbows can have a large impact on the pressure drop. If the pressure drop is too high, the unit will not make the required NOx or input due to the increased pressure drop. The burner capacity is reduced about 6% for each 1" of pressure drop.

f. Determine the location of the FGR shutoff valve (linkage systems only). It can be mounted in either the vertical or horizontal run, but it must be near the top of a vertical run

to reduce the potential for condensation collection. If the valve is mounted in a horizontal run, the valve shaft must be horizontal (so condensation does not collect in the bearing) and the actuator motor must be on top of the valve (with insulation between the line and drive motor). Also, there must be a condensation drip leg in the horizontal run before the shutoff valve to remove any condensation.

g. Determine if pipe reducers are needed for the connection to the FGR control valve and the FGR shutoff valve.

h. The duct must be properly supported, handling both the weight of the duct and to control the thermal expansion and contraction.

CAUTION
UNCONTROLLED CONDENSATION CAN CAUSE PREMATURE FAILURE OF THE CONTROL VALVES, FAN AND MOTOR. ADEQUATE MEANS MUST BE PROVIDED TO REMOVE CONDENSATION FROM THE SYSTEM. COLD STARTUP WILL GENERATE SIGNIFICANT AMOUNTS OF CONDENSATION.

The supports may need to be anchored to provide this stability in the FGR duct.

i. The FGR duct is normally made from schedule 40 pipe because it is easily obtainable and inexpensive. Schedule 20 pipe can also be used for this application.

j. The duct components must be seal welded, flanged or screwed together to provide an air tight duct. Air leakage into the duct will prevent the system from working properly. It is sufficient to only inspect the welds for a proper seal, they do not need to be leak tested.

10. Draft and Stacks

Stacks and breechings must be designed to maintain a relatively constant draft at the boiler outlet without large

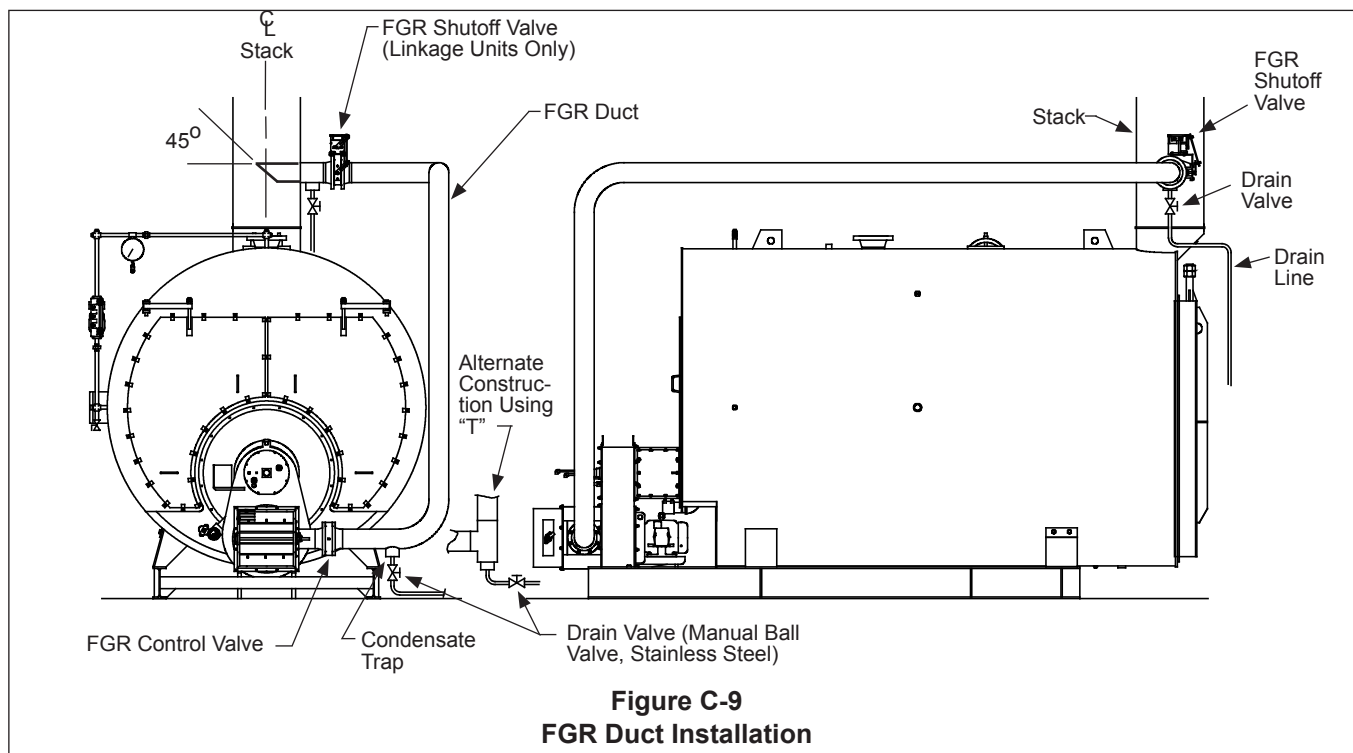

Figure C-9
FGR Duct Installation

variations. The draft at the boiler outlet should be maintained within +/- 0.1" wc. at low fire and up to +/- 0.25" at high fire, with intermediate draft proportional to firing rate. More important than the actual draft is the variation in draft at any given firing rate. For example, a tall stack or multiple units in a single stack may have different draft conditions depending on the outside temperature and the number of units running. The draft variation at any given firing rate should be controlled to within +/- 0.1" wc.

The stack should be designed to avoid wind influences from adjacent structures as well as preventing the flue products from entering inlet ducts, windows or other occupied areas. It should be of sufficient height to extend above the roof of the building or adjoining buildings to avoid down drafts in the stack or the possibility of carrying combustion gases to undesirable locations. Local codes should be checked for criteria on heights and exit velocities.

The breeching should be designed to be as straight and short as practical, to minimize pressure fluctuations. Smooth bends, gradual transitions, low velocities and tight construction are all important. Round breechings are preferred to square or rectangular ducts because they are more efficient and less likely to generate noise on the flat side due to resonance. The size should be based on a maximum velocity of 30 ft/sec. Changes in direction must be as slow as possible. Circular elbows should be of at least a four piece construction with a centerline radius that is at least double the duct diameter (use three times the duct width for square ducts). The breeching should have a slight upward elevation (about 1" per foot) towards the stack to help induce a draft. Figure C-10 shows the total BHP that can be fired within different breeching diameters. These can be multiple boilers of different size.

with care. The ducts should never be connected at a 90 degree angle, but rather a 45 degree angle where the flows will easily join each other. When connecting multiple boilers into a single breeching, the breeching size must be increased to accommodate the larger flow rates before the introduction of the added flow. These breeching size changes must be gradual, with no more than a 10 degree slope change in the duct. When multiple breechings are connected into a common stack, their locations must be staggered to prevent the flow of one breeching interfering with another.

**Figure C-10
Maximum BHP in a Breeching**

Breeching Diameter (D)	Total BHP
16	200
18	300
20	400
22	500
24	700
26	900
28	1100
30	1400
32	1600
34	1900
36	2200
38	2500
40	2900
42	3200

CAUTION
OIL BURNING EQUIPMENT SHALL BE CONNECTED TO FLUES HAVING SUFFICIENT DRAFT AT ALL TIMES, TO ASSURE SAFE AND PROPER OPERATION OF THE BURNER.

The connection of the breeching to the stack or multiple boilers to a common breeching or stack must be done

Tall stacks can generate large drafts, and in fact the amount of the draft is related to the stack height. Also, systems with multiple boilers can have draft variations that are well beyond the desired level. These conditions must be corrected to allow the burner to work properly, or the draft variations will cause combustion problems. Controls can be added to compensate for this draft, and bring it back into the desired level. The barometric damper is the most common and least expensive control. Several barometric dampers can be added to provide the total correction to the system draft.

**Figure C-11
Method of Connecting
Breechings and Stacks**

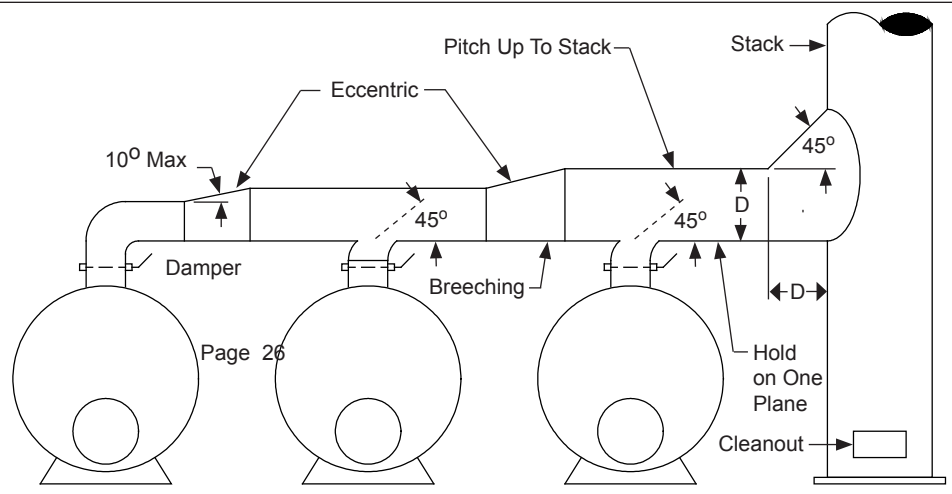

Draft controls are also available to regulate the draft by controlling an outlet damper. The speed of response is critical to allow these units to work correctly. If the draft control does not operate much quicker than the burner changes rate, the result may be large swings in draft as the control attempts to catch up with the burner. A feed forward control is the best means of performing this control. If there are large drafts due to tall buildings, special consideration must be given to the type of damper needed to regulate this draft, and the response of the control to maintain the proper draft.

11. Electrical System

The burner is supplied as standard, with a remote control panel. The panel is either intended for floor or wall mounting. The proper location will allow the operator to see the burner operate while manning the controls. In some areas, there are local regulations that define where the control panel must be mounted in relation to the vessel.

The control panel must be securely attached to either the floor or the wall. This should include lag bolts into the floor or wall.

The wiring diagram for the specific job should be followed for the connections to the panels and external equipment. The National Electric Code, Canadian Electrical Code, Part 1 or similar code for other jurisdictions should be followed.

The following list covers the standard acronyms used on wiring diagrams:

AUX.	– Auxiliary
CB	– Circuit Breaker
C.C.W.	– Counter Clock-Wise
C.W.	– Clock-Wise
CR()	– Control Relay
FGR	– Flue Gas Recirculation
FTS	– Fuel Transfer Switch
GND	– Ground terminal
H.W.C.O.	– High Water Cut Off
INT	– Interlock
L	– 120V line
L.F.H.	– Low Fire Hold switch
L.W.C.O.	– Low Water Cut Off
MR	– Manual Reset
N.	– 120 V Neutral
N.C.	– Normally Closed
N.O.	– Normally Open
P.L.F.S.	– Proven Low Fire Start
P.O.C.S.	– Proof Of Closure Switch
SW.	– Switch
TDR	– Time Delay Relay

D. Fuel and Electrical Systems

- | | |
|--|---|
| <ol style="list-style-type: none"> 1. Gas Systems 2. Gas Pilot 3. Air Atomized #2 Oil 4. Heavy Oil 5. Fuel-Air-Ratio Controls | <ol style="list-style-type: none"> 6. Electrical Controls 7. Operating and Modulating Controls 8. Flame Safeguards |
|--|---|

The burner can be equipped with a wide variety of different components and operating systems to control the fuel, air, modulation and safety. This section describes how these systems operate and their common components.

Each of the applicable systems must be completely understood prior to operating any equipment. In addition to the basic principles defined here, the component details and specific combination of components on your specific unit must be fully studied and understood. The fuel diagrams, wiring diagram, component manuals and bill of materials for the unit must be included in the study.

1. Gas Systems

All gas fuel systems have a common group of components, including the pressure regulator, shutoff valves, gas control valve and pressure switches. In addition, some systems use a vent valve, pressure switches and proof of closure switches. The type and location of these components can vary with the different applicable regulations, insurance and component supplier.

Figure D-1 shows the common gas trains arrangements used on the HDRS burner line. There may be other local or job site requirements that can alter the components in addition to those outlined in this summary.

All gas and oil systems for the HDRS burner are full modulating. The two gas safety shutoff valves are controlled by the flame safeguard to provide safe control of the fuel flow.

The gas control valve is a butterfly valve used to control

the flow of gas from the low fire to the high fire input. The butterfly valve is driven by a fuel cam (linkage system) or a direct coupled actuator. There are different types of gas control valves used, which may use mechanical low fire stops and/or may be internally ported as a smaller size. High turndown burners will require smaller valves with higher pressure drops to provide adequate control at low fire.

A vent valve is provided in some applications to allow gas that may leak past the first valve to escape to a safe point of discharge. **Vent valves are not used on propane fuels that are heavier than air or fuels that could be toxic.**

A gas pressure regulator is used to provide a constant supply pressure to the gas train and butterfly control valve. This constant pressure through a variable orifice in the gas control valve obtains consistent gas flow rates. The regulator must be capable of operating through the full range of flows and pressure with consistent and steady pressures. The regulator may be located upstream of the safety shutoff valves or integral with the second safety shutoff valve.

The high and low gas pressure switches are used to detect an improper gas pressure situation and will prevent the burner from firing under these conditions. The low gas pressure switch is located near the supply of gas to the gas train, to detect a loss of supply pressure. The high gas pressure switch is located before the metering valve to detect a surge in pressure to the burner.

The gas train is designed to work with the pressure avail-

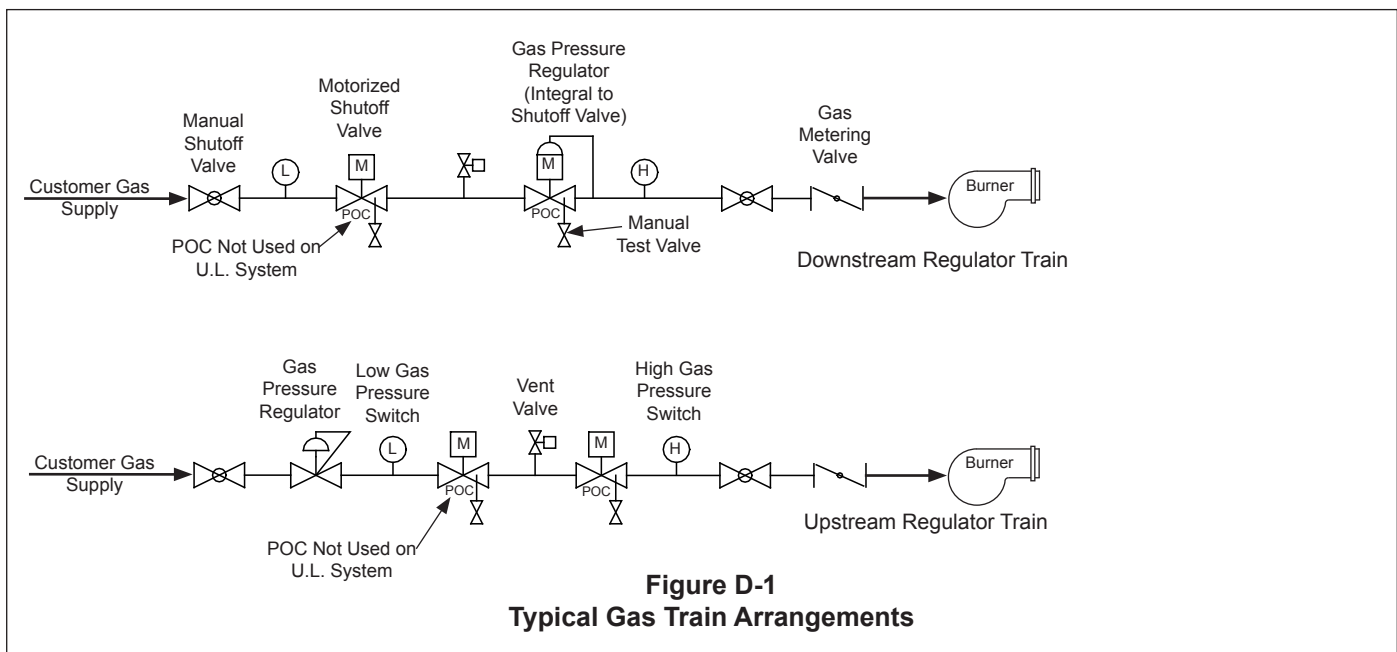

**Figure D-1
Typical Gas Train Arrangements**

able at the job site. This supply pressure generally refers to the pressure available at the entrance to the gas train, which is the pressure supplied to the gas trains shown in Figure D-1. The supply pressure may vary depending on the operation of the unit, in which case a minimum and maximum pressure are needed to define the supply pressure. The maximum pressure is the static pressure, or the pressure in the line when there is no flow. The leading components of the gas train are selected to operate up to these pressures. The minimum, or dynamic pressure is that pressure available when the unit is operating a full rate, or the reduced pressure due to the flow in the line. The gas train is sized to this pressure, so that it can deliver the required flow to the burner with this available pressure. The job site supply pressures must be consistent with the pressures listed on the burner material list.

The regulated gas pressure is that pressure required to overcome the pressure drops in the piping, firing head and furnace pressure to deliver the required flow at high fire. Usually, one of the first steps in setting up gas combustion is to adjust the regulator to get rated capacity. This regulator is usually at the beginning of the train, but in some cases, it can be integral to the second shutoff valve. The pressure drops and regulated pressures will be different in these two designs.

The manual valves are provided to lock out the fuel flow during off times and during initial startup checkout. They provide an added level of safety and can simplify maintenance.

The gas piping can play a critical role in the operation of the system. Throughout the system, the piping must carry the required flow without significant loss of pressure. If the drop is too high, there may not be enough pressure to operate the burner a full capacity. This is especially true between the gas train and the burner, where the pressure is lowest. The piping between the train and burner should have a minimum number of elbows and / or turns to prevent high pressure drops.

2. Gas Pilot

Figure D-2 show the typical gas pilot systems. Like the gas trains above, they have the common components of a pressure regulator and shutoff valve. The gas line connects upstream of the gas pressure regulator in the gas train.

The gas pilot is positioned behind the diffuser, with the pilot flame passing through the diffuser. The flame must be

large enough for the Flame Safeguard to detect the pilot flame and allow the burner to start. This also insures that there is sufficient pilot flame to ignite the main fuel.

The gas pilot can operate with either natural gas or propane. Different internal orifices are used to regulate the gas flow and maintain the same pilot size with the two different fuels.

3. Air Atomizing #2 Oil

An air atomizing system uses compressed air to atomize the oil. The oil pump and oil pressure regulating valve are optional and may be provided by others.

Figure D-4 shows a schematic of the air atomizing #2 oil system. The oil nozzle has two inputs, oil and air. Oil is supplied to the system at 125 PSIG. An optional remote pump assembly may be used, or it can be provided by other systems. In either case, a backpressure regulator is required to provide a constant pressure to the system.

The oil metering valve regulates the flow of oil to the nozzle and is used to vary the oil flow rate from low to high fire. Modulation is obtained by a fuel cam (linkage system) or by a direct drive actuator.

An air compressor is used to supply air for atomization. The air compressor is provided as a separate assembly and is field piped to the burner. The compressor should be located as close as possible to the burner to prevent loss of airflow. Also, the piping should be done to minimize the use of elbows and turns that result in pressure loss.

The atomizing airflow rate is regulated by the bleed valve, which can bleed off the excess air not required for good atomization. In some systems, especially with lower turndown rates, the bleed valve is set manually and does not vary. In other systems, especially with higher turndowns, the bleed valve is modulated with firing rate, by connection to the jackshaft or by a direct drive actuator.

4. Heavy Oil

Fuels that have a high viscosity require heating to bring the viscosity into the range of 100 SSU for good atomization. These oils are classified as ASTM No. 4 through No. 6 fuel oil. The HDRS burner can be equipped to handle these oils. (Note: Flue Gas Recirculation for low NOx cannot be combined with high sulfur heavy oil operation due to the corrosive and contaminated properties of these fuels).

Figure D-5 shows a schematic of a heavy oil system. Similar to the No. 2 oil system, the oil nozzle has two inputs, oil

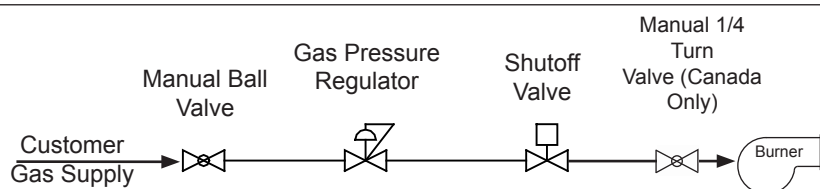

Figure D-2
Gas Pilot Train Arrangements

and air. Oil is supplied to the system with a remote pump assembly (Figure D-5). The pressure regulator is used to provide a constant pressure to the system.

An oil heater is provided between the pressure regulator and the nozzle, to maintain the desired oil temperature. This is a trim heater, which means that it is used to provide a temperature rise of about 30°F and a separate heater is used to provide any additional temperature rise (upstream of the oil pump). A temperature switch is used to cycle the electrical supply to the trim heater to maintain the desired temperature.

A temperature gauge is provided downstream of the trim heater to monitor the temperature of the oil.

The metering valve regulates the flow of oil to the nozzle and is used to obtain the low to high fire rates. The “Oil Supply Heating System” block in Figure D-5 (downstream of the oil pump) represents a typical location for the primary heater in a #4 or #5 oil system, where the suction line can be directly connected to the tank, if the oil viscosity is under 750 SSU. For higher viscosities, the primary heater and circulating pump must be located upstream of the equipment shown. A primary oil heater and pump set can be installed and piped in many different ways. Figure D-5 simply shows the requirement for a primary heater and should not be use as a piping design.

The air compressor is provided as a separate unit and should be mounted close to the burner with a minimal amount of piping and turns to restrict the air flow. The air-flow rate is regulated by the bleed valve, which can bleed off the excess air not required for good atomization. The bleed valve is a modulating valve when the burner operates at high turndowns.

The oil temperature is an additional variation in the combustion setup of a heavy oil burner. While the real issue is the viscosity of the oil, generally the temperature is simply adjusted to obtain good combustion. The following temperatures are typical values for different grades of fuel:

Grade of Oil	Viscosity Range @ 100° F	Oil Supply to Burner		Req'd Oil Temp at Nozzle
		Temp (°F)	Press (PSIG)	
# 2	32 - 138	40 - 80	125	-
# 4	150 - 300	50 - 80	125	100 - 140
# 5	350 - 750	70 - 150	125	125 - 200
# 6	900 - 9000	160 - 180	125	200 - 230

- Notes:**
1. The temperature must be adjusted to obtain a viscosity of 100 - 150 SSU at the oil nozzle.
 2. The oil must be heated to within 30° F of the final temperature as supplied to the burner.

5. Fuel-Air-Ratio Controls

All HDRS burners are full modulation. That means that they can modulate from a lower input to a higher input, based on a measured need for more or less input. The system that adjusts the fuel and air flow is called fuel-air-ratio controls and is covered in this section.

For proper operation, the rate of fuel and air flow must be closely matched for clean and efficient combustion. Too little combustion air and not all of the fuel will be burned, wasting fuel and increasing emissions. Too much air and the energy is wasted in heating this excess air to a relatively high stack temperature.

There are two common types of fuel-air-ratio controls, single point positioning (linkage) and parallel positioning (linkageless). The linkage system uses mechanical shafts and connection links to physically tie the air and fuel control valves together. A modulating motor is used to modulate the valves from low to high fire by providing a 90 degree rotation that matches the firing rate required (see section 7). A long shaft, called the jackshaft is used to distribute this 90 degree rotation to each valve. Linkage arms are connected from the jackshaft to the valve. By adjusting the positioning of the linkage, the air and fuel valves can be set to match each other. A fuel cam is used to provide some improved flexibility in adjusting the intermediate fuel rates, to match the air damper settings. If the unit has FGR, the FGR control valve will be tied together with the other valves to provide the correct flow at each firing rate.

The parallel positioning (linkageless) system uses independent electric actuators for each fuel, air and FGR valve. These are driven by a controller, which is programmed to set the correct position of each valve at multiple firing rates. This system offers more flexibility in adjusting the valves, including low and high fire positions and different FGR rates for each fuel.

An optional multiple position modulation motor can be used on a linkage system to provide different low and high fire settings for the different fuels, expanding the turndown capabilities of individual fuels.

6. Electrical Controls

The burner is provided with a junction box on the burner and free standing control panel as standard. The unit specific wiring diagram shows the wiring details of all these components, including the interconnecting wiring that may be required in the field. The motor starters for the oil pump and air compressor (if provided) are also included inside the control panel.

In some cases, the burner wiring diagram shows the interconnection of all the vessel safety and operating controls, like the low water cutoff. In other cases, these are shown on a separate diagram supplied by the vessel manufacturer. In all cases, these controls must be integrated together.

7. Operating and Modulating Control

Burner operation, for on-off cycling and modulation are controlled by the boiler steam pressure or hot water temperature variation from set point. Parallel positioning systems generally use sensors to measure temperature or pressure and are programmed in a unique method, not covered in this manual. Refer to the control manual, provided with the burner, for complete details on setting the controls.

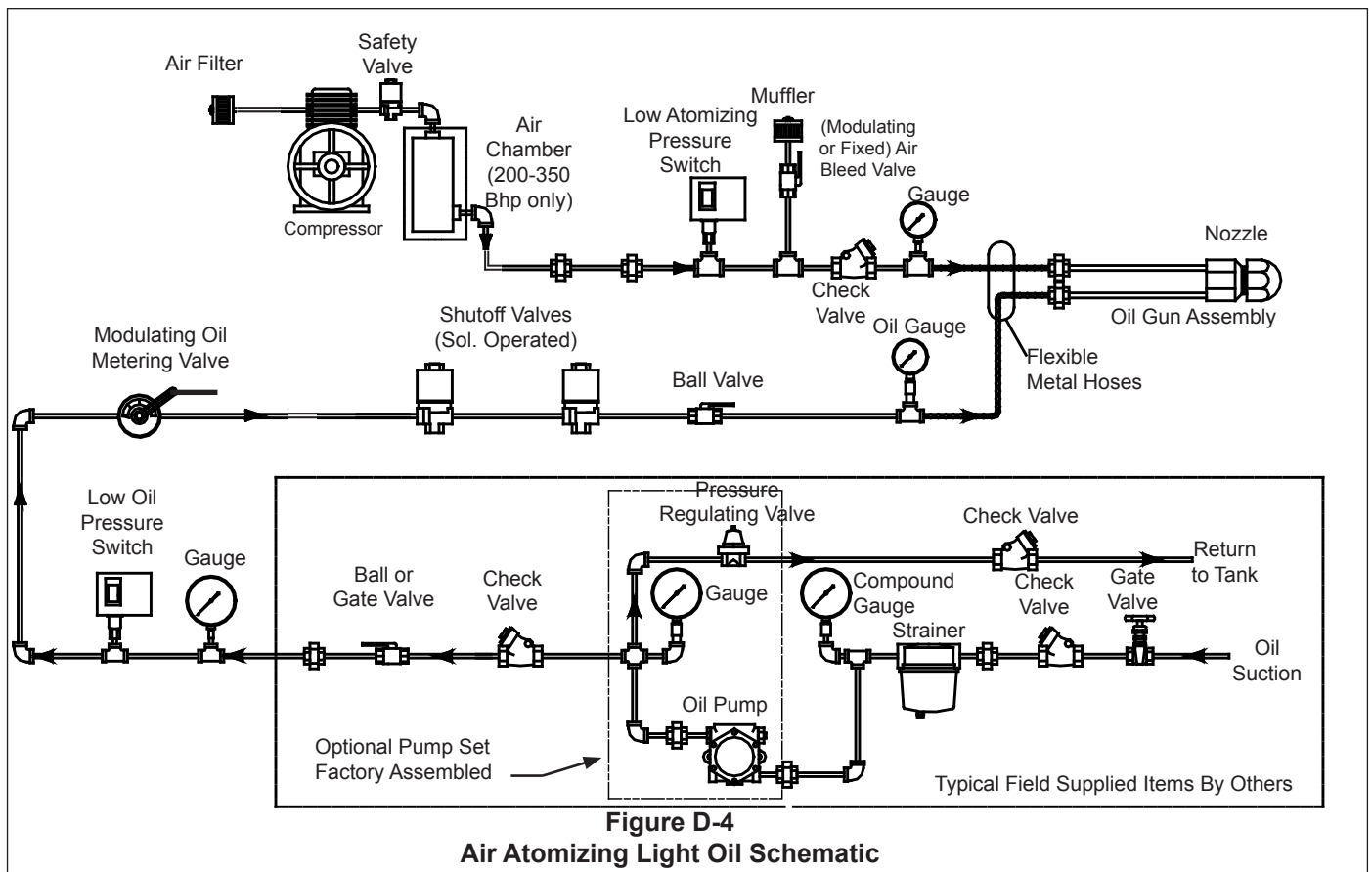

The standard equipment will include a high limit control, an operating control and a modulating control (not normally supplied with the burner). All of these controls are piped to the steam or hot water piping connected to the vessel. These three controls must be adjusted to function together or the burner will operate inefficiently and provide poor system response. If excessive on-off cycling occurs, the components will wear out prematurely. Figure D-6 shows the relationship between the temperature or pressure and burner firing rates.

The Operating Control senses the temperature or pressure and automatically turns the burner on to initiate the startup sequence when the temperature or pressure drops below the “Burner On” point (“B” on Figure D-6) and initiates the shut down sequence when the load is satisfied and the temperature or pressure rises above the “Burner Off” point (“A” on Figure D-6).

The high limit control senses the hot water temperature (vessel outlet) or steam pressure. It is used as a safety limit to turn the burner off if the operating control fails. If this limit is tripped, the burner will remain off and the limit control will have to be manually reset. The high limit control should be set sufficiently above the operating control (pressure or temperature) to avoid nuisance shutdowns. The high limit control cannot be set above the temperature rating of the vessel or connected piping. This point is indicated on the far right of Figure D-6 and represents the highest temperature or pressure available.

The modulating control senses the temperature or pressure and signals the modulating motor to set the fuel and air

input rates at a level consistent with the indicated temperature or pressure. An increasing load will cause the temperature or pressure to drop and the modulating motor will sense this lower level and increase the fuel and air input accordingly, starting modulation from low fire at point “C” and arriving at high fire at point “D” (Figure D-6). This control must be set to allow normal shutdown at low fire.

As Figure D-6 shows, there should be clear separation between each of the control points for the system to work properly. If the controls are positioned too close to each other, or even overlapping, the burner will have excessive ON-OFF cycling that reduces efficiency, increases wear and can cause premature failure of the components. Standard burner motors in the HDRS-RF size range should not cycle on and off quickly (refer to NEMA standards for maximum cycling frequencies).

8. Flame Safeguards

Several different FSG (Flame Safeguards) are offered for the HDRS-RF. They all perform the common function of controlling the process of pre-purge, pilot trial for ignition, main trial for ignition and flame safety as well as monitoring limit switches and sensors. The actual details of operation can vary. The manual for the specific FSG is included with the burner and should be studied carefully prior to installation, startup or operation.

The operating sequence, especially the sequence of when the limit switches are checked, will be an important tool in troubleshooting the burner.

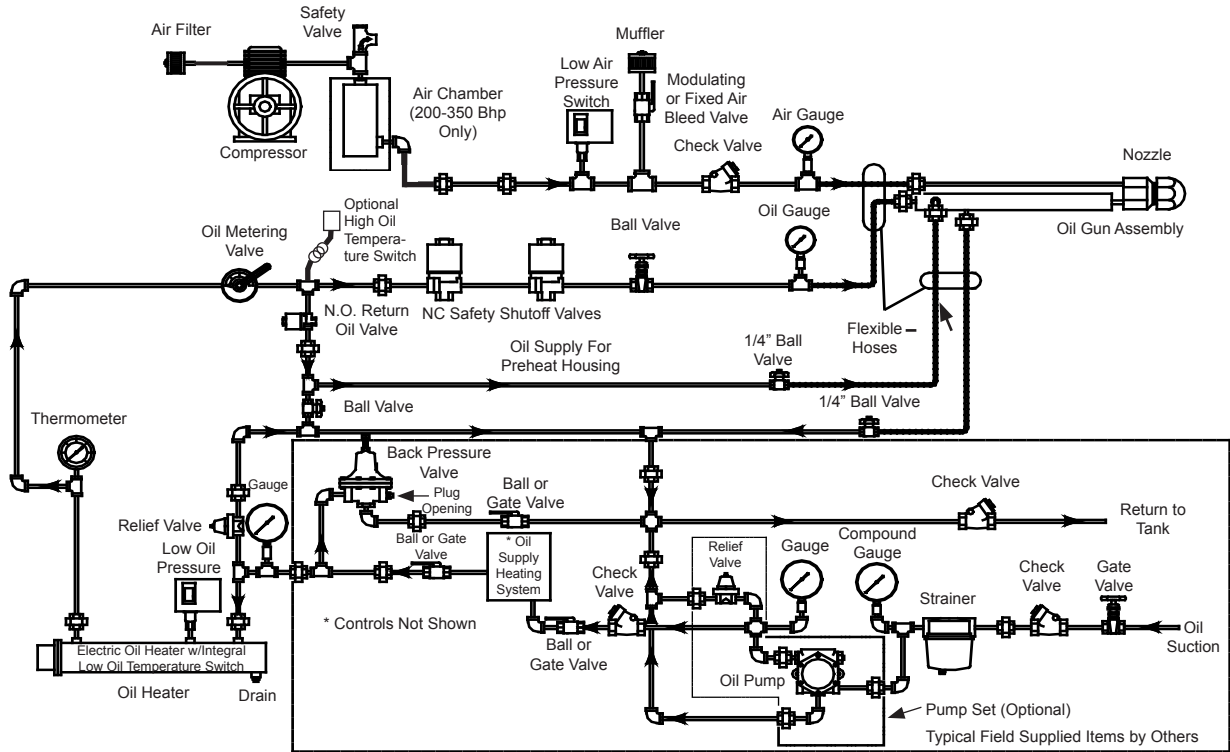

Figure D-5
Air Atomized Heavy Oil Schematic

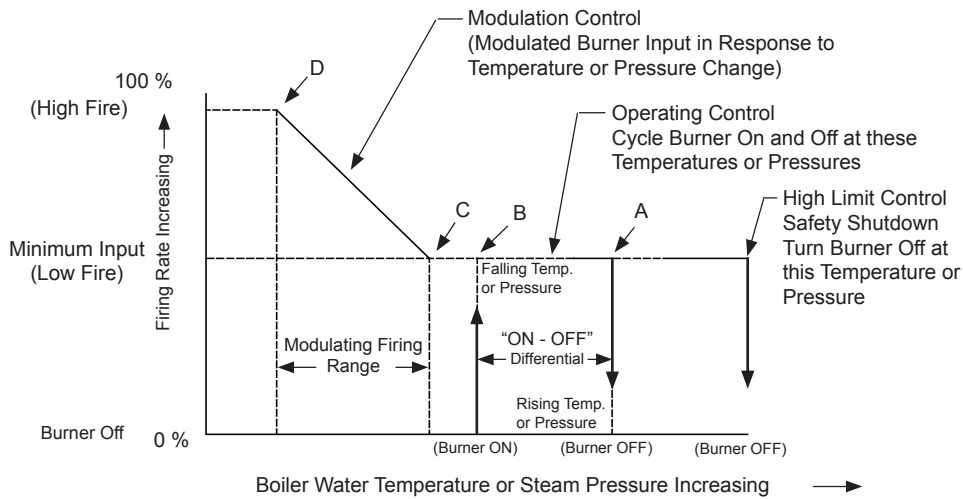

Figure D-6
Operating and Modulating Control

E. PRELIMINARY ADJUSTMENTS

1. Visual Inspection
2. Burner drawer checkout
3. Motor Rotation
4. Fuel, FGR and Air Control
5. Fuel Cam Adjustments
6. Air Damper Adjustments
7. Pilot and Scanner Adjustments
8. Gas Train Adjustments
9. Oil Train Adjustments
10. Air Proving Switch Adjustments
11. Operating and Modulating Controls

The burner is adjusted at the factory to expected initial firing positions, but will need to be adjusted for the specific application. Some smaller burners will be test fired in a test vessel to better find initial settings, and some may even be test fired in the new vessel provided with the burner. Each of these will provide some initial settings, but will not cover differences in the furnace pressure, air density, fuel properties and other conditions that must be covered by field adjustments and combustion testing. In addition, several checks and adjustments are required prior to startup. This section covers these preliminary checks and adjustments.

- The oil lines are tight.

2. Burner Drawer Checkout

The access cover on the head extension should be removed to inspect the burner drawer assembly and mounting to insure that all components are secure and in their proper position. Figure E-1 shows the location of the components in the burner drawer. Some components can be adjusted to improve combustion and can operate through a range of dimensions. Other components, like the pilot, must be in their identified position to work properly.

WARNING

ADJUSTMENTS DEFINED IN THIS SECTION ARE ONLY INTENDED TO COVER THE INITIAL BURNER STARTUP. FINAL ADJUSTMENTS AS DEFINED IN SECTION F MUST BE DONE TO PROVIDE THE FULL SAFETY OF THE SYSTEM. FAILURE TO PROPERLY ADJUST THE CONTROLS COULD RESULT IN INJURY OR DEATH.

CAUTION

BURNER ADJUSTMENTS SHOULD ONLY BE PERFORMED BY TECHNICIANS TRAINED AND EXPERIENCED IN THIS WORK. FAILURE TO USE PROPERLY TRAINED AND EXPERIENCED TECHNICIANS COULD RESULT IN EQUIPMENT DAMAGE, PERSONNEL INJURY OR DEATH

1. Visual Inspection

The shipment and installation of the burner can result in loose connections, bent arms and other changes. The burner should be visually inspected for any unusual conditions before operating.

- All wiring connections are tight. Test pulls on wire show them to be tight.
- All fuel lines are tight.
- Burner is mounted to vessel and floor, with all bolts secured.
- The linkage and cams are tight.
- The linkages, cams and valve actuators are aligned and have not been bent during installation.
- The air damper, FGR line and control valves are tight.

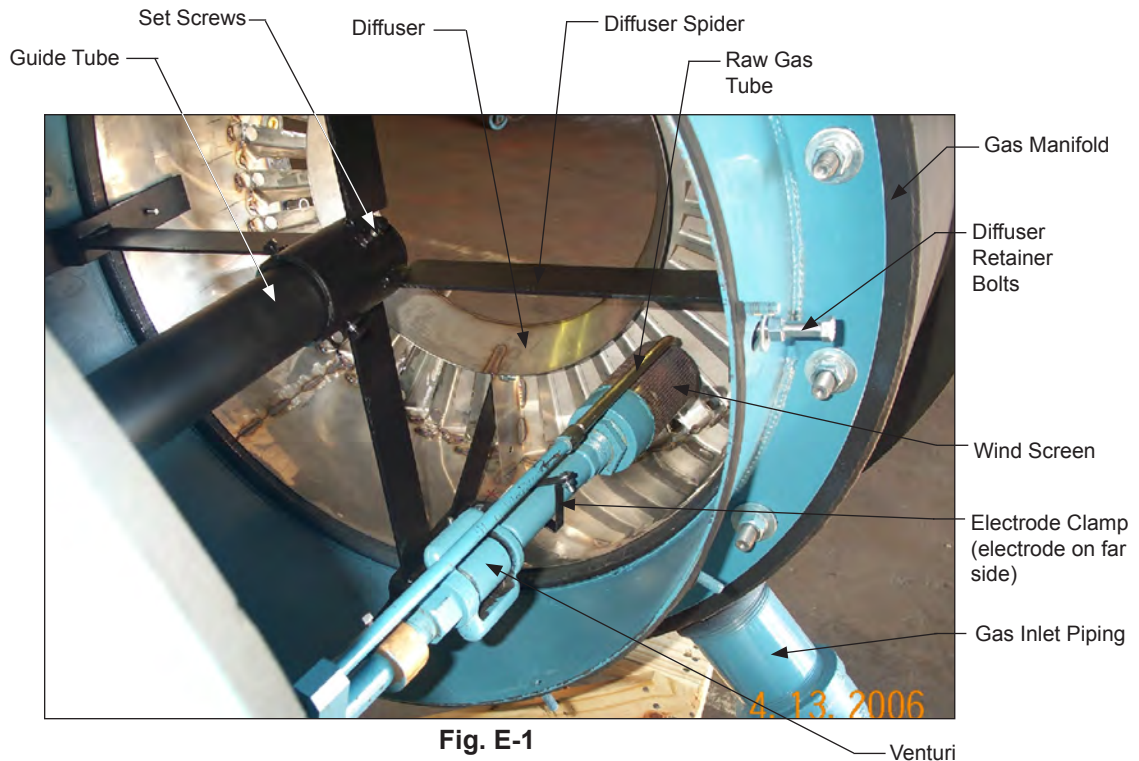

**Fig. E-1
Burner Drawer Setup
(shown with access cover removed)**

The burner is adjusted at the factory with initial settings for this application. These settings may be different than the initial values in the chart, these positions are based on test firing and should be used.

The burner drawer must be inspected to insure that the components have not shifted or come loose during transit or installation. The burner drawer access cover must be removed to perform this inspection. The following is a list of checks that should be done.

- The scanner tube should be aimed above the pilot and towards the main flame. It must not be able to see a small pilot flame that would not ignite the main flame. A pilot turndown test must be performed to insure this safe operation.
- The diffuser should not be crooked and must have the same spacing to the gas spuds throughout its circumference.
- The pilot should be at a 45 degree angle, located a few inches behind the diffuser. the pilot flame will pass through the diffuser fins to ignite the main flame
- The ceramic blanket must be in position between the front of the gas housing and the refractory, all the way around.
- The word "TOP" should appear on the top of the oil gun, on the outside of the backplate.

3. Motor Rotation

The combustion air fan and pump motors must be checked for proper rotation. The motors can be momentarily powered by pressing the mechanical actuator on the starter. This should be done with a wood block for insulation value.

The combustion air fan rotation is marked with an arrow on the windbox. The rotation can be observed within the motor to verify correct rotation, or if this is not accessible, the burner drawer can be removed to directly observe the fan. The oil pump has a slot between the motor and pump where the rotation can be observed. An arrow on the pump shows the correct rotation. The direct drive air compressor can rotate in either direction, but belt driven compressor must rotate as the arrow indicates.

4. Fuel, FGR and Air Control

The fuel and air valves have initial positions set at the factory. Differences in air density, fuel properties and supply pressure will require tuning of the burner. The initial positions of the air damper, FGR valve, gas valve and oil valve should be adequate for initial startup, but must be checked so that movement did not occur during shipment or installation. If this is a linkage burner, the linkage should be adjusted to allow for modulation from low to high fire, with each valve opening 45 to 90 degrees. This should be checked by one of the two methods below.

Honeywell Brand Modulation Motor:

The modulating motor can be operated by removing the cover, and removing the yellow wire to drive the motor to the high fire position. Connecting the yellow wire will cause the motor to drive to low fire position. This is a low voltage (24 VAC) wire that can be handled safely, however, care must be used as high voltage is also present.

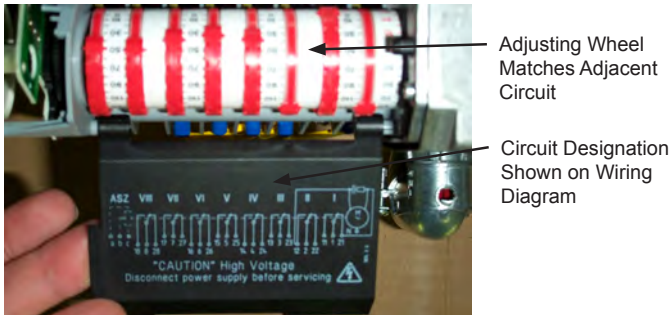

Figure E-2 Multiple Setpoint Modulation Motor (Landis)

Siemens Brand Modulation Motor:

This motor has multiple set points, one for gas and one for oil. Removing the cover will expose a manual/auto switch

that will allow the motor to be cycled manually to check the linkage and valve positions.

CAUTION
IN MANUAL POSITION, PILOT AND LOW FIRE SETTINGS DO NOT LIMIT TRAVEL ON THE MULTIPLE SET POINT MODULATION MOTOR. MONITOR AND DECREASE TRAVEL IF THE VALVES APPROACH FULL TRAVEL TO PROTECT THE VALVES FROM DAMAGE.

Figure E-2 shows the internal settings of the multiposition modulation motor. Each adjustable cam setting is related to an electrical connection (or circuit in motor). These circuit numbers are listed on the wiring diagram so that the low and high points of each fuel are identified. These would be adjusted independently to obtain the input rates. The valves and linkage should operate smoothly without strain or jerky actions. If this occurs, check for binding linkage and rod ends that are not within their range of motion and readjust as required.

If the burner is equipped with FGR, the FGR valve will modulate with the fuel and air valves and it should travel from the near closed low fire position to a position that is about 45 to 90 degrees open at high fire. Dual fuel units can have additional controls, preventing or limiting FGR from flowing during oil firing. Some FGR units (designed for 30 ppm gas) will be equipped with a potentiometer in the control panel that will allow the shut-off valve to partially open and allows a small amount of FGR to flow when firing oil. This keeps the oil input close to the gas input (lowering the FGR rate increases the combustion air rate). The oil combustion is generally better when some FGR is used at low rates thus NOx level will be reduced. On combination fuel, linkage burners with FGR, the

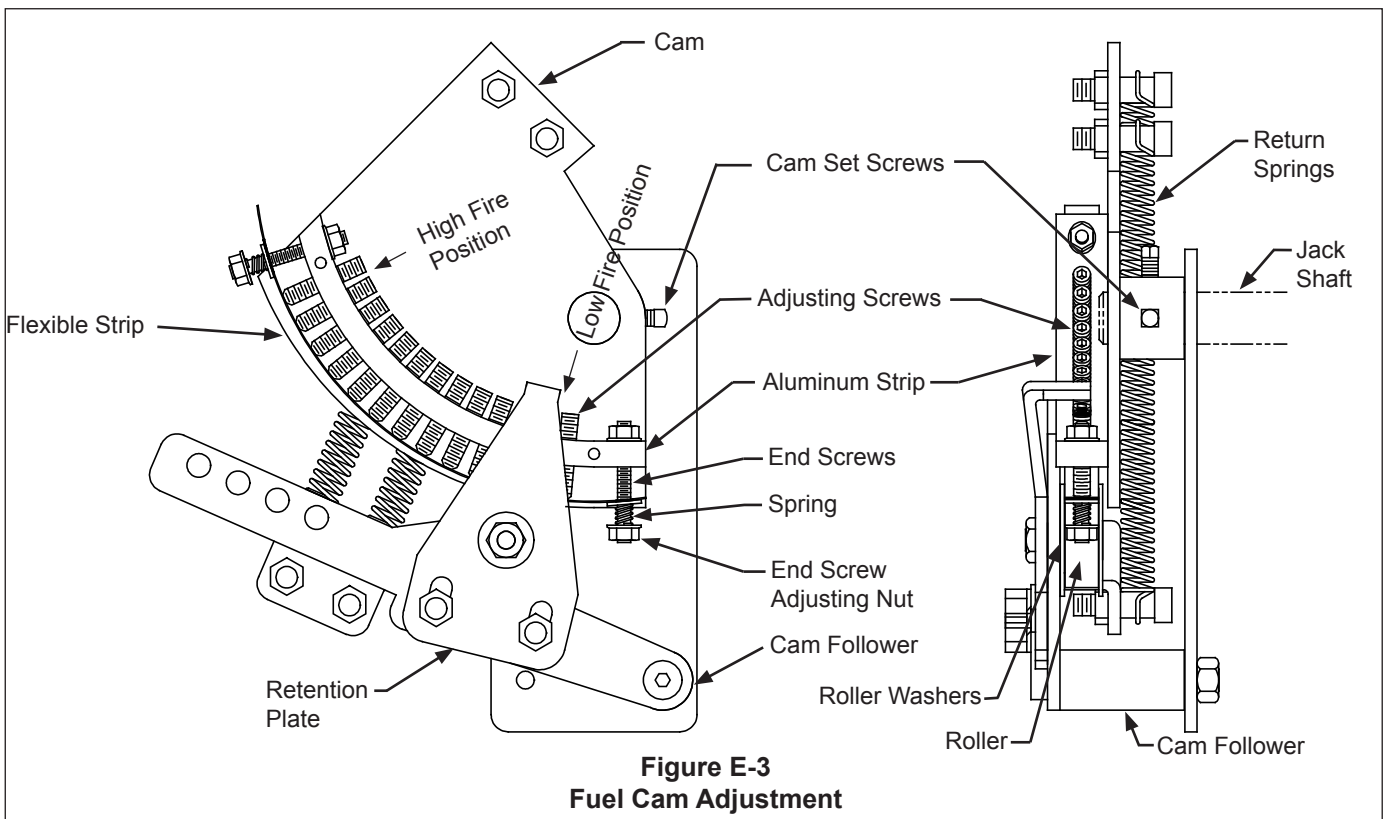
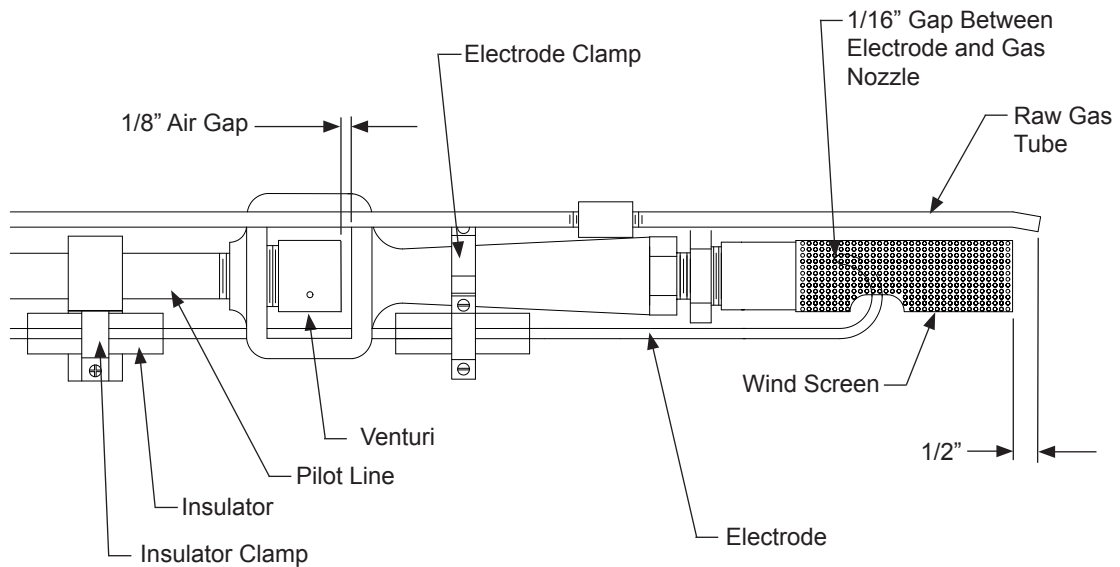
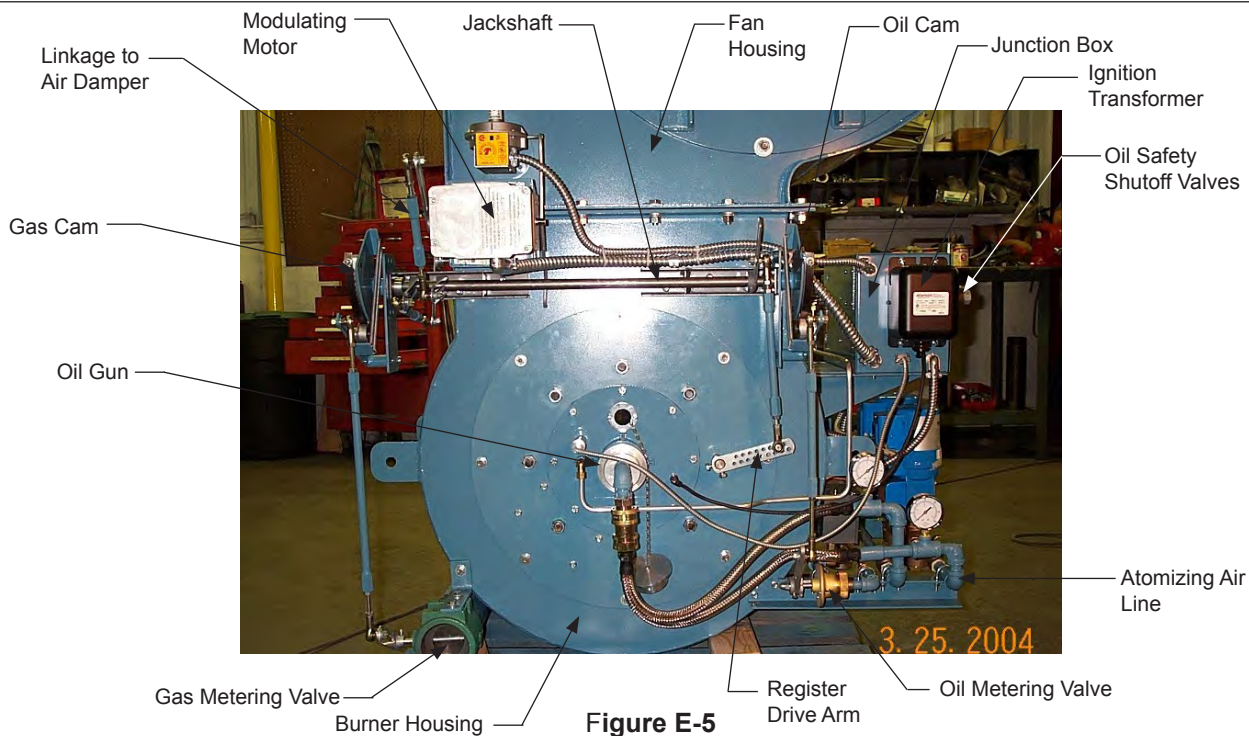

Figure E-3
 Fuel Cam Adjustment



**Figure E-4
Pilot Assembly**



**Figure E-5
HDRS-RF Burner
Linkage Control System**

shutoff FGR valve may require adjustment for oil firing. If the gas NOx level is 60 ppm, no adjustment is needed and both fuels will operate with the same FGR setting.

5. Fuel Cam Adjustments

The fuel cam needs to be checked for correct travel and alignment. Positions can change during shipment and installation and they must be reviewed prior to startup. The fuel cams are mounted to the ends of the jackshaft assembly. A cam follower link follows the profile established by the adjusting screws and drives the fuel valve. A thin metal band is used between the screw and cam follower to provide a smooth profile. The adjusting screws are backed

by compressed nylon inserts, which provide a resistance to turning.

The cam (Figure E-3) should be checked for the following conditions:

- a. At the low fire position, the roller should be between the first two adjusting screws. If not, adjust the position of the cam accordingly, making sure to maintain the same low fire fuel valve position.
- b. When the linkage is modulated from low to high fire, the roller must stay in the center of the adjusting screws within 1/8". If needed, the two cam set screws can be loosened and the cam moved to center it on the roller.

- c. At high fire, the roller should be between the last two adjusting screws.
- d. The adjusting screws should form a smooth contour with no jumps between the screws.
- e. In preparation of startup, the retention plate can be removed temporarily to make it easier to adjust the screws.

THE RETENTION PLATE MUST BE REPLACED WHEN SETUP IS COMPLETE.

If the unit is equipped with a parallel positioning system (linkageless), the control valves can be positioned and operated in a similar manner, but accomplished through the controller. Refer to the instruction manual for details.

CAUTION

LINKAGE AND ACTUATOR MOUNTINGS CAN BE BENT OR MOVED DURING SHIPMENT AND INSTALLATION. THEY MUST BE CHECKED PRIOR TO OPERATION AND ANY FAULTS CORRECTED. FAILURE TO CORRECT A MISALIGNED CONTROL WILL RESULT IN PREMATURE FAILURE.

6. Air Damper Adjustments

Low fire is set at the factory to a near closed position. High fire position is typically 30° to 60° open, depending on the application. The combustion settings will determine final position.

Linkage adjustments are done as with any other equipment. The damper linkage is configured with a slow opening profile, so that the change in airflow from low fire is more gradual than a typical air damper. Extreme linkage setups that attempt to slow the damper opening off of low fire are not required.

7. Pilot and Scanner Set Up

The pilot assembly is located on the end of a gas pipe that is inserted through the burner drawer assembly. A bracket mounted to the guide tube is used to hold the pilot end in the correct position. A separate gas tube and ignition wire runs parallel to the pilot pipe, with brackets and insulators throughout the length.

The electrode is positioned 1/16" from the end of the gas nozzle of the pilot, to generate the spark to ignite the pilot. The wind screen protects the pilot flame base from air turbulence, and the raw gas tube provide extra gas for a larger pilot flame size.

The venturi is adjustable to allow air to mix with the gas in the pilot prior to ignition. The venturi is normally set for a 1/8" air gap, but is adjustable to more or less air.

The gas pilot regulator should be adjusted for a gas pressure of 1 psi (Figure E-6). When adjusting the pilot in the "Test" mode, the operating time of the pilot should be limited to 30 seconds to prevent it from overheating the diffuser.

The pilot flame should be large enough to easily pass

through the diffuser and rise above the pilot. The flame size should be no larger than that required for a good scanner pickup with separation from the pilot and a good pilot turndown test. An oversized pilot flame can cause premature failure of the diffuser.

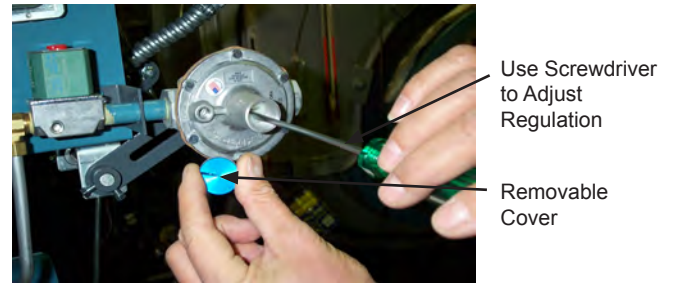

Figure E – 6 Gas Pilot Regulator Adjustment

The scanner is mounted to a pipe that is attached to a rotating ball. The scanner can be positioned to see the swirl flame from the pilot, but to drop out if the pilot flame is too small.

8. Gas System Adjustments

The gas pressure regulator should be set to the required gas pressure. If this value is not known, a value of approximately 50% over the high fire gas manifold pressure (given on burner nameplate) can be used for the initial setting. It will be adjusted at startup to obtain the rated capacity during setup (Figure E-7).



Figure E – 7 Main Gas Pressure Regulator Adjustment

The low gas pressure switch (if provided) should be set for an initial value of 50% below the lowest expected gas pressure. The high gas pressure switch (if provided) should be initially set at 50% above the highest valve expected at that point. See section C for location of switches (Figure C-4).



Figure E – 8 Gas Pressure Switch Adjustment

9. Oil System Adjustments

The oil pressure supply to the burner should be set at 100 PSIG initially, and final adjustments made to support the high fire oil input, similar to the gas pressure regulator. The regulator is adjusted by removing the cap and turning the regulator screw clockwise (cw) to increase pressure and counterclockwise (ccw) to decrease pressure. The low oil pressure switch (Figure E-10) should be set for a pressure of about 25 PSIG lower than the regulated pressure.

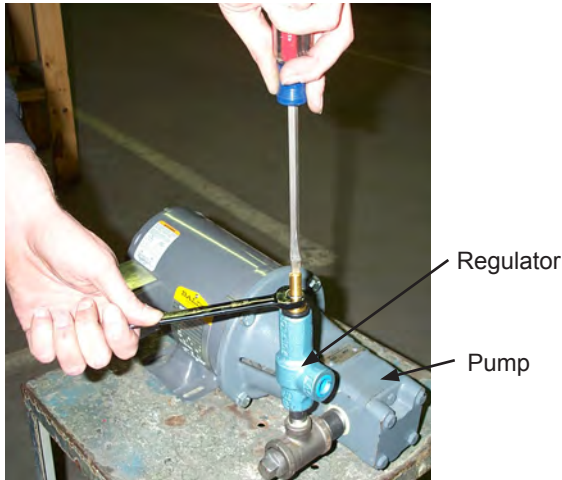

Figure E - 9 Oil Pressure Regulator Adjustment

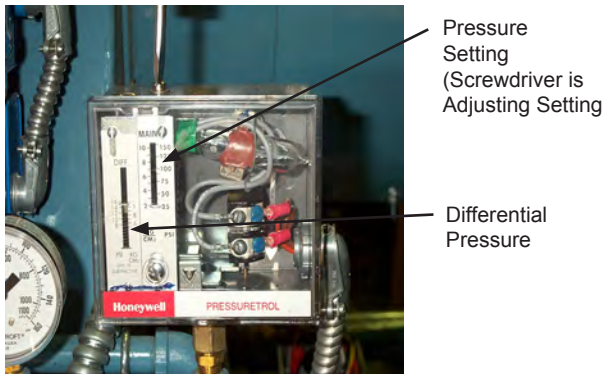

Figure E - 10 Low Oil and Atomizing Air Pressure Switches

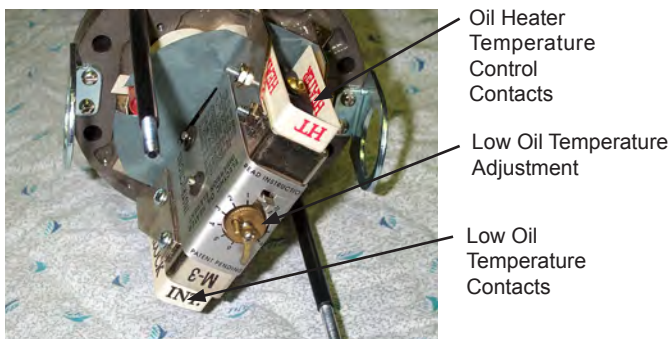

Figure E - 11 Low Oil Temperature Switch

On heavy oil units, the electric trim heater should be set for a temperature that corresponds to the grade of fuel being burned,

#4 oil	150°F
#5 oil	180°F
#6 oil	200°F

The low oil temperature switch (Figure E-11) should initially be adjusted to 25°F below the value listed and the high oil temperature switch (Figure D-5) should be set at 25°F above the values listed.

10. Air Proving Switch

The air proving switch has been adjusted at the factory for an initial setting. If this switch trips during initial startup, turn the adjustment screw ccw two full turns to reduce the trip pressure setting (Figure E-12).

The air proving switch may be located on the burner. In some cases, a pressure sensor may be used in place of the switch, depending on the type of controls used.

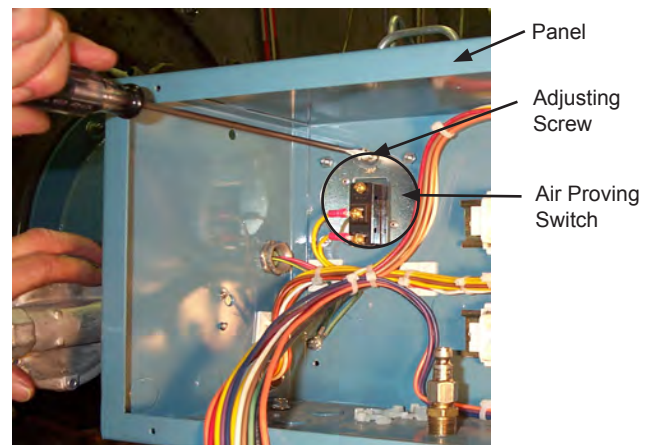

Figure E - 12 Air Proving Switch Adjustment

11. Operating and Modulating Controls

The operating controls will not be used during the burner setup, except that the high limit and operating controls can cycle the burner off and should be set for the highest allowable pressure for the application.

The high limit control should be set at the maximum temperature or pressure allowed for the boiler vessel or piping. The operating control should be set at a high enough pressure to prevent this control from turning the burner off unless the operating temperature or pressure is at the maximum value. The modulating control should be set at a value below the operating control to prevent the unit from modulating immediately after starting.

F. STARTUP and OPERATING ADJUSTMENTS

1. Pre-start Checkout
2. Linkage Adjustments
3. Fuel Cam Adjustments
4. FGR Adjustment
5. Burner Drawer Adjustments
6. Single Fuel Setups
7. Combination Gas and Air Atomized #2 Oil
8. Combination Gas and Heavy Oil
9. Gas Setup
10. Air Atomized #2 Oil Setup
11. Heavy Oil Setup
12. Operating Control Adjustments
13. Limit Tests
14. Pilot Test
15. Burner Shutdown
16. Restart After Extended Shutdown

This section covers the startup and operating adjustments of the Webster Models HDRS burners.

WARNING

BURNER STARTUP, COMBUSTION ADJUSTMENTS AND LIMIT CONTROLS ADJUSTMENTS SHOULD ONLY BE PERFORMED BY TRAINED AND EXPERIENCED SERVICE TECHNICIANS. ATTEMPTING TO PERFORM THESE FUNCTIONS WITHOUT THE PROPER TRAINING AND EXPERIENCE CAN RESULT IN EQUIPMENT DAMAGE, PERSONAL INJURY OR DEATH.

Before proceeding with the startup and adjustment, be sure that the overall installation is complete. Review the boiler operating and installation manual, as well as all control manuals to verify that all equipment is ready for operation. These manuals must be read and understood prior to starting the equipment.

If you are not qualified to service this equipment, DO NOT TAMPER WITH THE UNIT OR CONTROLS - CALL YOUR SERVICEMAN.

At the conclusion of the startup, document valve and linkage positions, pressures and settings for future reference.

READ AND SAVE THESE INSTRUCTIONS FOR FUTURE REFERENCE.

1. Pre-Start Check List

Before starting the burner, a complete review of the installation, wiring and piping of the burner, boiler and all supporting equipment must be complete and all of these items must be ready for operation prior to starting. The following is a general review:

- _____ All wiring is connected. Test pulls on wire show them to be tight.
- _____ All fuel lines are connected and tight.
- _____ Pilot gas is connected.

_____ Burner is mounted to vessel and floor, with all bolts secured.

_____ The linkage is correct (in low fire position) and tight.

_____ The stack is connected and routed to the outside. Draft controls are installed and operational.

_____ Gas vent lines are connected and routed to the outside.

_____ Do not start the unit unless all cleanout doors are in place and secured.

_____ The vessel is completely installed, filled with water and operating controls checked.

_____ Support equipment is in place and ready (feed pumps, draft controls, steam/hot water systems, boiler limits and controls and feedwater systems).

_____ A load must be available for the burner startup and adjustment process. The burner must be operated at high rates for extended periods of time and the load must be capable of using this energy.

_____ A combustion analyzer with O₂ and CO (for gas) must be available to tune combustion. A smoke spot tester must be available for oil firing. If this is a low NO_x burner, a NO_x analyzer must be available. All of these analyzers must be recently calibrated and able to provide accurate readings.

_____ Other test equipment, including manometers, gauges and volt meter shall be available.

_____ Manometer or gauge on the gas manifold.

_____ Manometer or gauge before and after gas pressure regulator.

_____ Draft gauge or manometer (at stack outlet).

_____ Draft gauge or manometer for furnace pressure.

2. Linkage Adjustments

Adjusting the air damper and FGR control valve on a linkage system requires an understanding of linkage setups. The rate of change for the fuel valve, air damper and FGR valve must be matched by how the linkage is setup. If the air damper, air register and/or FGR valve opens too quickly, the flame may become unstable or the NO_x levels may not meet the requirements. There are a few general guidelines that should be followed in setting up the linkage of a burner,

a. The linkage must provide the correct stroke of the valve, from low to high fire. Increasing the length of the drive crank arm (B) or decreasing the length of the driven crank arm (C) will increase the valve travel. To reduce valve travel, decrease B or increase C (Figure F-1).

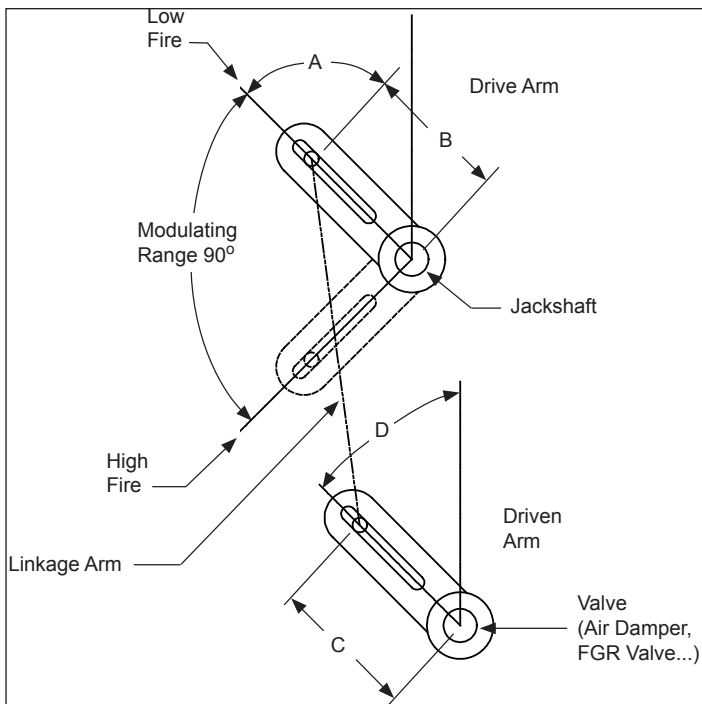

Dim	Smaller	Larger
Angle A	Slower LF driven arm travel (D)	Faster LF driven arm travel (D)
Length B	Reduce driven arm travel (D)	Increase driven arm travel (D)
Length C	Increase driven arm travel (D)	Reduce driven arm travel (D)

**Figure F-1
Linkage Adjustments**

b. Decreasing the angle of the drive arm will slow the initial valve travel (and speed up the travel at high fire). This would be done to get the air damper to match the fuel valve action.

3. Fuel Cam Adjustments

The cam is used to adjust the intermediate fuel rate with the low and high fire settings done by the linkage connections. The intermediate rates can be adjusted by turning the adjusting screws in the clockwise direction to increase fuel input and decrease the % O₂ level in the flue gases. Turning the adjustment screws counterclockwise will decrease fuel input and increase % O₂ in the flue gases.

The following guidelines should be used for adjusting the cam:

- When adjusting the screws, the adjacent screws must also be adjusted to provide a smooth contour from screw to screw. When complete, the flexible strip between the adjusting screws and the roller must come in contact with each screw, providing a smooth transition from low fire to high fire.
- The end screws (or nuts) can be adjusted to hold the strip against the screws, but should not deform the strip.
- There should be no upsets in the profile, where the flex-

ible strip is required to move to a screw position where it is initially not in contact with the screw. Also, the movement from one screw to the next cannot be too large (more than 1/8"). This will cause the strip to flex and will lead to premature failure of the strip.

d. The adjusting screws have a limited range of adjustment. They can be turned in until they are flush with the aluminum bar and adjusted out until the side washers of the roller contact the aluminum bar.

e. If any adjusting screw does not turn with some resistance, the cam must be replaced.

f. When the cam adjustment is complete, the retention plate must be installed. The retention plate will help insure that the fuel valve position will not get far from its ideal position, even with interference or sticky valve operation.

WARNING

IF THE CAM ADJUSTING SCREWS DO NOT HAVE RESISTANCE TO TURNING, THE CAM SHOULD BE REPLACED, AS THE SCREWS MAY CHANGE POSITION. FAILURE TO CHANGE A DEFECTIVE CAM MAY RESULT IN INJURY OR DEATH.

CAUTION

LARGE CHANGES FROM ONE ADJUSTING SCREW TO ANOTHER WILL RESULT IN PREMATURE FAILURE OF THE CAM AND MAY PREVENT THE BURNER FROM OPERATING PROPERLY.

g. If the contour has a sharp rise in the cam screw profile, trying to open the valve very quickly in the first few screws, the linkage should be readjusted to cause the air damper to open slower (make the jackshaft drive arm more parallel to the linkage rod). Likewise, the opposite contour can be corrected by speeding up the air damper drive (Figure F-1). The final cam screw profile should be close to the profile of the cam with no abrupt changes.

4. FGR Adjustments

Flue gas is recirculated back into the burner to reduce the flame temperature, which reduces the NO_x level. High quantities of flue gas result in lower NO_x levels, but can also result in flame instability if there is too much FGR. Natural gas fuel can handle larger quantities of flue gas than oil and can have much lower NO_x levels as a result. Generally, the NO_x levels only apply to gas firing and oil firing is not adjusted for NO_x levels. There may be exceptions to this, and the order details should be reviewed to identify any special combustion requirements.

Dual fuel units may need additional adjustments and compensation to handle the different FGR rates between natural gas and #2 fuel oil. Units that require gas NO_x levels above about 45 ppm can operate with the same quantity of FGR on both fuels and no additional controls or adjustments are needed. Burners equipped

with linkageless systems can be adjusted for individual air and FGR settings on both fuels and can easily handle these variations, even with lower NO_x levels. Linkage burners operating at 30 ppm NO_x (natural gas) are equipped with a potentiometer in the control panel that will allow the shut-off valve to partially open and allows a small amount of FGR to flow when firing oil. This keeps the oil inputs close to the gas input (lower FGR rates increases the combustion air rate). The oil combustion is generally better when FGR is used at low rates resulting in a lower NO_x level.

Linkage dual fuel units may also be equipped with the optional multiple set point (Siemens) modulation motor in addition to the above potentiometer. This motor allows for different low and high fire settings on gas vs oil to obtain the correct airflow for each fuel and optimize the turndown on gas.

The quantity of recirculated flue gas can be adjusted with the FGR valve, the relationship of the settings of the air louver, air register and FGR valve will also change the amount of FGR. To reduce the quantity of FGR, close the FGR valve or open the air louvers and close the air register a few degrees. To increase the quantity of FGR, open the FGR valve or close the air louvers and open the air register a few degrees.

On a dual fuel unit, the natural gas should be done first to properly set the FGR. Once gas is setup, oil can be set.

For dual fuel linkage systems, the following guidelines should be used:

- A 60 ppm system can be adjusted with the same FGR rate on both fuels. The FGR control valve is set on gas and oil follows that setting.
- A 30 ppm system uses the FGR limiting potentiometer (located in the control panel) to obtain a partial flow of FGR when firing oil. The FGR control valve is set when firing gas. The FGR limiting potentiometer is adjusted to improve combustion but not cause instability. The combustion needs to be checked at several firing rates.
- Under 30 ppm, separate gas and oil operating points are established in the modulating motor. Parallel positioning (linkageless) systems allow all of the valves to be positioned independently for each fuel. For this reason, the setup sequence can be more flexible.

5. Burner Drawer Adjustments

The burner drawer has several adjustments built into the design that allow the combustion to be tuned during operation. While this can simplify the combustion tuning process, care must be used to retain the relative position of other components during this sequence. If these adjustments are required, follow the sequence listed to perform the adjustments.

Before any adjustments are made, the position of each component must be marked. A felt tip pen or a combination of masking tape and another type of pen can be used. Most burner adjustments can be made by opening the access cover on the head extension.

- a. To adjust the diffuser to gas spud dimension, loosen the

four set screws on the diffuser spider, and the four bolts holding it to the head extension. The diffuser can now be moved in or out. Tighten the screws and bolts before operating the unit.

- b. To adjust the oil nozzle to diffuser position:

- Loosen the two setscrews locking the oil gun lines to the aluminum end cap of the oil gun.
- Adjust the oil nozzle to obtain the best combustion.
- Watch for spray back on the diffuser when the gun is pulled too far back. The flame may appear good but carbon will quickly develop on the diffuser.
- Tighten the two setscrews on the oil tubes locking it into position.

If the burner drawer needs to be removed for better access to components, follow the following steps:

- a. If the unit is a gas - oil combination burner, remove the oil and atomizing lines from the oil gun and remove the oil gun by removing the bolts from the aluminum end cap that holds the oil gun to the guide tube, the oil gun and cap will now slide out of the guide tube.

Remove the pilot line from the pilot and pilot train and place it out of your way were it will not be damaged.

Loosen the set screw or screws that hold the flame detector in place. Do not loosen the ball swivel that the flame detector mounting bracket is mounted to.

Remove the bolts holding the back plate of the burner drawer assembly to the register plate and remove the burner drawer assembly.

- b. The burner diffuser will not come out with the burner drawer assembly. To remove the burner diffuser, remove the inspection plate on the side of the cylinder, that connects the burner housing to the burner combustion head, and remove the diffuser through the inspection opening.

To re-install the burner drawer, simply work the procedure in reverse.

6. Single Fuel Setups

Single fuel burners can be adjusted following the procedures outlined in Section 9 for gas firing; Section 10 for Air atomized #2 oil and Section 11 for heavy oil firing.

The procedures for each of the systems (linkage, cams, FGR) must be completely understood and followed as part of the setup process.

7. Combination Gas and Air Atomized #2 Oil

Combination burners, firing both gas and oil, require some compromises in the setup because they share common controls for both fuels. Air atomized #2 oil firing can have turndowns and air damper positions very similar to gas firing, simplifying the setup. If the burner is equipped with FGR, gas must be started first to set the FGR control valve positions to obtain the correct NO_x performance. If there is no FGR, either fuel can be started first, however the setup cannot be finalized

until both fuels have been reviewed to determine the air damper and air register positions. Follow the setup procedures defined in Section 9 for gas setup and Section 10 for air atomized oil setup.

If the burner is equipped with an optional multiple set-point modulating motor, the low and high fire rates, as well as light off rates, can be set independently for each fuel. In this case, the gas is adjusted first, to set the air damper locations for gas firing, as defined in Section 9. Once gas is set, oil is setup as defined in Section 10, except that the multipoint modulating damper motor is adjusted to bring the low fire air setting to match the oil needs.

There are several different options available that can alter the exact setup details, and these must be evaluated prior to startup so that the procedures can be adjusted accordingly. The procedures given are for linkage systems. Parallel positioning (linkageless) systems allow for much more flexibility in the fuel, air and FGR settings on each fuel, and can be tuned to better match each fuels needs. The setup details for linkageless controls will follow the same general sequence, but differ in specifics for setting the valve positions.

8. Combination Gas and Heavy Oil

Combination burners, firing both gas and oil, require some compromises in the setup because they share common controls for both fuels. Heavy oil burners cannot operate with FGR and do not have this adjustment. If the burner does not have a multiple setpoint modulating motor or linkageless control, oil must be set first, as the air damper and air register positions will be determined by this setup. With the multiple setpoint modulating motor, gas must be set first, as it will dictate the damper positions. In either case, setup cannot be finalized until both fuels have been reviewed to determine the air damper and air register positions. Follow the setup procedures defined in Section 9 for gas setup and Section 11 for air atomized heavy oil setup.

There are several different options available that can alter the exact setup details, and these must be evaluated prior to startup so that the procedures can be adjusted accordingly. The procedures given are for linkage systems. Parallel positioning (linkageless) systems allow for much more flexibility in the fuel, air, register and FGR settings on each fuel, and can be tuned to better match each fuels needs. The setup details for linkageless controls will follow the same general sequence, but differ in specifics for setting the servos positions.

9. Gas Setup

- a. Place the burner switch in the "OFF" position
- b. Place the "Auto-Manual" switch in the manual position. If this is a combination fuel burner, make sure the fuel selector switch is on "GAS".
- c. Place the manual flame control potentiometer in the

MIN (low fire) position

d. Close the downstream manual shutoff valve (closest to the modulating valve) on the gas train.

e. Turn the electrical power on for the burner, boiler and related components.

f. Verify that the gas metering valve is nearly closed, the air register should be around 20 degrees open, the vent valve (if equipped) is operating and the gas pilot valve is not open (the solenoid will hum and feel warm).

g. If equipped with FGR, verify that the FGR control valve is in the near closed position. A linkage system should have the shutoff FGR valve in the closed position.

h. Turn the burner switch on. This will start the blower motor and initiate the prepurge cycle.

i. When the prepurge sequence is complete and the low fire start switch is made, the pilot valve and ignition transformer will be energized and the pilot flame should be visible through the sight port. The flame signal should be strong and steady.

j. When the pilot flame is established, the flame safeguard will energize the main gas valve (indicated with the Fuel On Light). This operation of the main fuel valves must be visually checked by observing the valve stem operation.

k. After the timer has completed the trial for main flame, the burner will go out on alarm (the closed manual gas valve prevented the burner from lighting). At this time, the gas valves must be visually checked to verify that they have closed. This test sequence proves the proper operation of the primary control.

l. Press the reset button and restart the burner. When the pilot has started, open the manual gas valve to allow the main flame to start.

m. If equipped with FGR, the shutoff FGR valve should open on a linkage system, after the main flame has been proven. The timing can be adjusted with the time delay inside the control panel, so that the FGR shutoff valve opens as soon as the main flame is established. The control valve of the linkageless system should move from closed to a low flow position after the light off or golden start has timed out.

NOTE: If the burner is not operating as indicated, follow the troubleshooting guide steps to determine the problem and corrections required.

n. After a few seconds, the combustion analyzer should have an accurate reading of the O₂ in the stack. Figure F-2 shows the typical range of O₂ at different firing rates, and the burner should be adjusted to be within this range. Rough settings for low and mid fire combustion settings are adequate at this time. Once the high fire is set, the other settings can be fine tuned.

- Turning the cam screw in will add fuel, making it richer and reducing the O₂ level.

- Turning the cam screw out will reduce the fuel input, increasing the O₂ level.

If equipped with FGR, the NO_x level should be close to the desired NO_x, as required by the specific order. The FGR valve can be opened to decrease the NO_x level, or closed to increase the NO_x level.

o. Operate the burner until the boiler is warmed up, and near the operating pressure or temperature. Increase the

firing rate, using the manual potentiometer, while monitoring and adjusting the O₂ level. Adjust the gas pressure regulator as needed to reach the high fire input.

p. If equipped with FGR, adjust the FGR valve as needed to obtain the approximate NO_x level.

q. Adjust the high fire input to match the maximum input listed on the rating label. At high fire, the gas butterfly valve should be at least 70 degrees open (more if available gas pressure is low), and the gas pressure regulator adjusted to obtain the rating. The input should be measured using the following equation:

Calculating Natural Gas Input

Gas MBH =

$$\text{HHV} \times \left[\frac{\text{Patm} + \text{Pgas}}{29.92} \right] \times \left[\frac{520}{\text{Tgas} + 460} \right] \times \left[\frac{\text{measured ft}^3/\text{sec}}{3600 \text{ sec/hr}} \right]$$

Where:

MBH = 1000's of BTU/M input

HHV = Higher heating value of gas, BTU/cubic feet

Patm = Atmospheric pressure in inches Hg

Pgas = Gas pressure before gas meter in inches Hg
(inches HG = PSIG x 2.04)

Tgas = Gas temperature at the flow meter, in degrees F

Measured ft³ = volume of gas measured by meter
sec = Time for measured ft³ to flow through meter

Note: Some gas meters require a 6 inch wc correction to Pgas. Consult your meter calibration data.

NOTE: The listed manifold pressure is only an approximate value and can vary with operating conditions and normal tolerances. The fuel flow rate must be measured to obtain an accurate input value.

r. Adjust the air damper to obtain the correct O₂ level.

s. If equipped with FGR, adjust the NO_x level to be about 10% below any guaranteed NO_x performance. A balance of the FGR control valve, air register and air damper are required to obtain the final result, as each can impact the other. If the FGR valve does not travel at least 50 degrees, the air louvers and the air register can be adjusted **so you can open the FGR valve further**. Modulate the burner to low fire, adjusting the O₂ level as the burner modulates.

u. Adjust the low fire input, using the fuel cam, air register and air damper adjustments. The linkage may need to be readjusted to obtain the correct relationship between the fuel valve, air register and air damper. (Figure F-1)

v. Re-adjust the midfire points for the correct O₂ level.

w. If equipped with FGR, adjust the NO_x levels at low and midfire rates to be about 10% under the guaranteed levels.

x. Adjust the low gas pressure switch to be 10% below the lowest expected gas pressure.

- With a gauge or manometer at the same location as the low gas pressure switch, modulate the burner to determine the firing rate with the lowest gas pressure.

- At the lowest gas pressure, adjust the low gas pressure setting up until the switch breaks and causes the burner

to shutdown.

- From the scale reading of the switch, adjust the setting to a pressure that is 10% lower than the shutdown pressure. For example, if the switch opened at 10 inches as indicated on the low gas pressure switch, the switch should be adjusted to a reading of 9 inches.

- Remove the gauge or manometer and plug the opening.

- Cycle the burner on and off to determine if the limit works properly.

- If the limit causes nuisance shutdowns because of small pressure drops during startup, reduce the pressure setting an additional 5%.

y. Adjust the high gas pressure switch to be 10% above the highest expected gas pressure.

- With a gauge or manometer at the same location as the high gas pressure switch, modulate the burner to determine the firing rate with the highest gas pressure.

- At the highest gas pressure, adjust the high gas pressure setting down until the switch opens and causes the burner to shutdown.

- From the scale reading of the switch, adjust the setting to a pressure that is 10% higher than the shutdown pressure. For example, if the switch opened at 10 inches as indicated on the high gas pressure switch, the switch should be adjusted to a reading of 11 inches.

- Remove the gauge or manometer and plug the opening.

- Cycle the burner on and off to determine if the limit works properly.

- If the limit causes nuisance shutdowns because of small pressure changes during startup, increase the pressure setting an additional 5%.

z. The burner should be operating at low fire to adjust the air proving switch. Turn the adjusting screw cw (in) until the burner trips out (shutdown caused by the air flow switch). Turn the adjustment screw ccw (out) 1 1/2 turns from the point of shutdown. Check the operation at higher rates.

10. Air Atomized, #2 oil Setup

The air atomized oil system has the potential for a large turndown range similar to gas and has the potential to be adjusted to different low fire rates. See the burner nameplate for details on actual rates for this burner.

If the burner is equipped with FGR and is a linkage system, the type of FGR control must be determined prior to starting. If this is a dual fuel burner, the FGR rate is determined by the NO_x performance on gas. A 60 ppm burner will operate with the same FGR rate on gas and oil. A 30 ppm unit will use the limiting potentiometer to slightly reduce the FGR rate on oil firing. For Oil only combustion, the NO_x level will be given on the burner detail sheet, and should be used to set the FGR control valve.

a. Place the burner switch in the "OFF" position.

b. Place the "Auto-Manual" switch in the manual position. If this is a combination fuel burner, make sure the fuel selector switch is on "OIL".

c. Place the manual flame control potentiometer in the min (low fire) position.

**Figure F-2
O2 levels**

% Rate	Natural Gas With FGR		Natural Gas No FGR		Oil	
	Min % O2	Max % O2	Min %O2	Max %O2	Min %O2	Max %O2
8	5.0	9.0	7.0	13	NA	NA
10	5.0	9.0	5.5	12	6.0	10.0
15	4.0	8.0	4.5	10	5.0	9.0
20	3.0	8.0	3.5	9	4.0	8.0
30	2.0	7.0	3.0	8	3.5	7.5
40	2.0	7.0	2.5	7	3.0	7.0
50	2.0	6.0	2.5	6	3.0	7.0
100	2.0	6.0	2.5	6	3.0	6.5

- d. Turn the electrical power for the burner, boiler and related components on.
 - e. Verify that the oil metering valve is at the nearly closed position and the air register is about 20 degrees open.
 - f. Turn the burner switch on. This will start the blower motor and initiate the purge cycle.
 - g. When the prepurge sequence is complete and the low fire start switch is made, the pilot valve and ignition transformer will be energized and the pilot flame should be visible through the burner sight port. The flame signal should be strong and steady.
 - h. When the pilot flame is established, the flame safeguard will energize the main oil valves (indicated with the Fuel On Light), and the burner should ignite at low fire. This operation of the main fuel valves must be visually checked by observing the valve stem moving up with a motorized valve or hearing the clicking noise from a solenoid valve.
 - i. If equipped with FGR, the shutoff FGR valve should open (after a short time delay) on a linkage system, after the main flame has been proven. The timing can be adjusted with the time delay inside the control panel, so that the FGR shutoff valve opens as soon as the main flame is established (10 to 15 seconds). The control valve of the linkageless system should move from closed to a low flow/low fire position after the light off or golden start timing is over.
- NOTE:** If the burner is not operating as indicated, follow the troubleshooting steps to determine the problem and corrective action.

WARNING

DO NOT ATTEMPT TO START THE BURNER WHEN EXCESS OIL HAS ACCUMULATED, WHEN THE UNIT IS FULL OF VAPOR, OR WHEN THE COMBUSTION CHAMBER IS HOT.

- i. After a few seconds, the combustion analyzer should have an accurate reading of the O2 in the stack. The O2 level should be between 4% and 8% (see Figure F-2 for O2 rates), and the nozzle oil press should be between 5 and 15 PSIG. Do not attempt to fine tune combustion until the high fire input has been set.
- If the burner is equipped with FGR, the FGR control valve or limiting potentiometer should be set for the approximate NOx level required.

- Turning the cam screw in will add fuel, making it richer and reducing the O2 level.
- Turning the cam screw out will reduce the fuel input, increasing the O2 level.
- The air damper should be positioned for the correct low fire settings.
- The atomizing air pressure can be adjusted using the air bleed valve.
- j. Operate the burner until the boiler is warmed up, and near the operating pressure or temperature (Figure F-3).
- k. Increase the firing rate, using the manual potentiometer, while monitoring and adjusting the O2 level. Adjust the cam, oil pressure and atomizing air pressure as needed to reach the high fire input.
- l. If the burner is equipped with FGR, adjust the FGR control valve or potentiometer as required to maintain the NOx level.
- m. At high fire (end of the modulating motor travel), adjust the high fire input to match the maximum input listed on the rating label. Using a flow meter, the fuel input may be measured using the following equation,

$$\text{Oil GPH} = \frac{[\text{Gal end} - \text{Gal start}] \times [3600 \text{ sec/hr}]}{[\text{measured sec}]}$$

Where Gal end = meter gallons at end of test
 Gal start = gallons at start of the test
 Measured sec = measured time of test
 GPH = Gallons of oil per hour

- n. If equipped with FGR, adjust the NOx level to be about 10% below any guaranteed NOx performance or if performance guarantee exists adjust the FGR to provide some added turbulence but not high enough to impact flame stability. A balance of the FGR control valve and air damper are required to obtain the final result, as each can impact the other. If this is a 30 ppm system, the FGR limiting pot should be adjusted to reduce the FGR rate for stable combustion, with the FGR control valve set when firing gas. If this is a 60 ppm system, no adjustment is necessary.
- o. Modulate the burner to low fire, adjusting the O2 level as the burner modulates.
- p. Adjust the low fire input, using the fuel cam and air damper adjustments.

- q. If the burner is equipped with FGR, adjust the NOx level according to the type of system (limiting potentiometer or matching gas).
- r. Re-adjust the midfire points for the correct O2 levels. The linkage may need to be readjusted to obtain the correct relationship between the fuel valve and air damper. See Figure F-1.
- s. If equipped with FGR, adjust the NOx levels at low and midfire rates to be about 10% under the guaranteed levels or as required for the gas firing.
- t. The burner should be operating at low fire to adjust the air proving switch. Turn the adjusting screw cw (in) until the burner trips out (shutdown caused by the air flow switch). Turn the adjustment screw ccw (out) 1 ½ turns from the point of shutdown. Check the operation at higher rates.

FIGURE F-3
Typical Atomizing Air Pressure

% Rate	Air Pressure
10	5 - 15
15	7 - 20
20	10 - 25
30	12 - 30
40	15 - 35
50	20 - 40
100	25 - 60

11. Heavy Oil Setup

CAUTION
WHEN WORKING WITH HEATED OIL, PROTECTIVE CLOTHING, INCLUDING GLOVES, SHOULD BE WORN TO PROTECT FROM BURNS.

The air atomized heavy oil system requires the additional adjustment of oil temperature in the burner setup. The temperature is adjusted to improve the viscosity for good atomization. Typically, this will be about 150°F for #4 oil, 180°F for #5 oil and 200°F for # 6 oil.

- a. Prior to startup, the oil system must be operating with the oil temperature to the burner (before the trim heater) within 20°F of the final temperature.
- b. Place the burner switch in the “OFF” position. If this is a combination fuel burner, make sure the fuel selector switch is on “OIL” and that the oil pump is running.
- c. Place the “Auto-Manual” switch in the manual position.
- d. Place the manual flame control potentiometer in the MIN (low fire) position.
- e. Turn the electrical power on for the burner, boiler and related components.
- f. The oil may take some time to get up to temperature. If the oil is cool, the ball valve downstream of the N.O. oil return valve (Figure D-6) can be opened to make it easier for the oil to circulate and reach operating temperature.
- g. Verify that the oil metering valve is at the nearly closed

position and the air register is about 20 degrees open.

- h. Turn the burner switch to “ON”. This will start the blower motor and initiate the prepurge cycle.

WARNING
DO NOT ATTEMPT TO START THE BURNER WHEN EXCESS OIL HAS ACCUMULATED, WHEN THE UNIT IS FULL OF VAPOR, OR WHEN THE COMBUSTION CHAMBER IS HOT.

- i. When the prepurge sequence is complete and the low fire start switch is made, the pilot valve and ignition transformer will be energized and the pilot flame should be visible through the burner sight port. The flame signal should be strong and steady.

- j. When the pilot flame is established, the flame safeguard will energize the main oil valves (indicated with the Fuel On Light), and the burner should ignite at low fire. This operation of the main fuel valves must be visually checked by observing the valve stem moving up with a motorized valve or hearing the clicking noise from a solenoid valve.

- k. After a few seconds, the combustion analyzer should have an accurate reading of the O2 in the stack. The O2 level should be between 4% and 8% (See Figure F-2 for O2 rates) and the nozzle oil press should be between 10 and 20 PSIG. Do not attempt to fine tune combustion until the high fire input has been set.

- Turning the cam screw in will add fuel, making it richer and reducing the O2 level.
- Turning the cam screw out will reduce the fuel input, increasing the O2 level.
- The air damper should be positioned for the correct low fire settings.
- The atomizing air pressure can be adjusted using the air bleed valve (Figure F-3).
- The oil temperature can be adjusted to obtain the best atomization.

- l. Operate the burner until the boiler is warmed up and near the operating pressure or temperature.

- m. Increase the firing rate, using the manual potentiometer, while monitoring and adjusting the O2 level. Adjust the cam, oil and atomizing air pressure and oil temperature as needed to reach the high fire input.

- n. At high fire (end of the modulating motor travel), adjust the high fire input to match the maximum input listed on the rating label. Using a flow meter, the fuel input may be measured using the following equation,

$$\text{Oil GPH} = \frac{[\text{Gal end} - \text{Gal start}] \times [3600 \text{ sec/hr}]}{[\text{measured sec}]}$$

Where Gal end = meter gallons at end of test
Gal start = gallons at start of the test
Measured sec = measured time of test
GPH = Gallons per hour

- o. Modulate the burner to low fire, adjusting the O2 level as the burner modulates.
- p. Readjust the low fire input, using the fuel cam and air damper adjustments.
- q. Re-adjust the midfire points for the correct O2 levels. The linkage may need to be readjusted to obtain the cor-

rect relationship between the fuel valve and air damper. (Figure F-1)

r. The burner should be operating at low fire to adjust the air proving switch. Turn the adjusting screw cw(in) until the burner trips out (shutdown caused by the air flow switch). Turn the adjustment screw ccw (out) 1 ½ turns from the point of shutdown. Check the operation at higher rates.

12. Operating Control Adjustments

The operating controls must be adjusted to properly cycle the burner “ON and OFF” and provide modulation. See Section E-11 for details. The controls should not force the burner into rapid “ON-OFF” cycles, as this will cause premature failure of the motor and operating equipment.

The operating control must be adjusted to provide the “ON” pressure or temperature desired. It must allow the burner to come on and start before the temperature or pressure drops into the modulating range. The “OFF” pressure or temperature must be sufficiently above the “ON” point to allow a reasonable run time.

The modulating control must be adjusted to start modulation at some reasonable point below the “ON” temperature or pressure and provide modulation to high fire at the lowest temperature or pressure.

13. Limit Tests

Once the burner has been started and the operating pressures and temperatures have been set, the limit switches need to be adjusted so that they will trip if the pressure or temperature exceeds the operating value, but will not trip with normal variations. The switch should be checked for proper operation by allowing the temperature or pressure to vary below (or above) the recommended level to insure that they provide safe shutdown before the burner operation is affected. In some high pressure or temperature switches, where the temperature or pressure cannot be set high enough to trip the switch, the switch can be checked by lowering the set point to prove that the switch will provide a safe shutdown.

The limit switches would include the air proving switch on the burner. Limits for gas operation could include the high and low gas pressure switches and for oil firing, the high and low oil pressure switches, high and low oil temperature switches and the atomizing air pressure switch. If in doubt about which limits are on a burner, refer to the wiring diagram that will show each item.

Limit switches need to be checked at regular intervals to ensure they are operating properly. See the maintenance section for details.

14. Pilot Test

Once the burner as been set for the firing rates intended for the burner, the pilot must be checked for proper operation and safety.

The minimum pilot test is done to insure that a pilot which can be seen by the scanner will light the main flame.

a. During a startup sequence, measure the time required

to light the main flame after the fuel valves have been energized. This will be used to monitor the test with reduced pilot.

b. Lock the flame safeguard into the pilot position (refer to the manual for the flame safeguard for this setting)

c. Adjust the gas pressure regulator to the pilot for a minimum value while still holding the minimum signal strength for the scanner.

d. Release the flame safeguard from the pilot position and allow it to cycle though the main flame proving sequence.

e. This reduced pilot must reliably light the main flame. Monitor the time from the main fuel valve opening and do not allow the burner to continue if the time is more than an additional two to three seconds from the initial time measured above.

f. Run through two or three cycles.

g. If this is a combination fuel burner, repeat the test on the other fuel.

h. Failures due to reduced scanner signal are also acceptable.

WARNING

THE MINIMUM PILOT TEST REQUIRES CLOSE SUPERVISION OF THE COMBUSTION PROCESS. FAILURE TO CLOSELY MONITOR THE MAIN FLAME TEST TIME COULD RESULT IN DAMAGE, INJURY OR DEATH.

i. If the pilot does not light the main flame under these test conditions, check and adjust the pilot as shown in figure E-1 and E-4.

The scanner must be tested for hot refractory pickup. This test is performed to make sure that the scanner does not see hot refractory that could be mistaken for a flame.

a. After the burner has been operating for some time at high input levels and the refractory in the vessel is hot, the burner should be cycled off while monitoring the scanner signal.

b. The flame signal should drop off quickly as the flame goes out and should be well below the minimum level (indicating a flame) at the end of the post purge cycle.

c. If the flame signal does not drop out as required, check the location of the pilot and scanner, as shown in Figure E-1. This may also indicate a faulty scanner or amplifier.

15. Burner Shutdown

Normal operation of the burner will allow the operating controls to shut the burner down when the load demand is satisfied. If the burner needs to be shut down for any reason, the “ON-OFF” switch can be used to quickly turn the burner off. This will instantly cause the fuel valves to close and start a post purge cycle to remove any unburned fuel from the vessel.

In an emergency shutdown, all fuel and electrical power should be de-energized or turned off to secure the burner. This would include the main power disconnect, the manual gas shutoff valve at the drop down line and if equipped, the manual oil valve to the nozzle.

It is recommended that the burner be manually driven to low fire before turning the burner off, as this reduces the dynamic and thermal stress. If the burner will remain off for some time, the manual fuel valves, fuel pumps and power supply should be turned off.

CAUTION

ALWAYS KEEP THE FUEL SUPPLY VALVE SHUT OFF WHEN THE BURNER IS SHUT DOWN FOR AN EXTENDED PERIOD OF TIME.

16. Restarting after Extended Shutdown

Extended shutdowns require the same startup process as those outlined above. In addition, the following advanced cleaning must be done,

- a.** The oil nozzle should be removed and cleaned. Use care in cleaning to preserve the sharp edges of the nozzle, which are required to maintain good atomization.
- b.** The oil filter and strainer must be removed and cleaned prior to starting.

CAUTION

DO NOT START THE BURNER UNLESS ALL CLEANOUT DOORS ARE SECURED IN PLACE.

G. MAINTENANCE

1. General
2. Physical Inspection
3. Fuel-Air-Ratio
4. Gas Fuel Systems
5. Oil Fuel Systems
6. FGR System
7. Combustion Air Fan
8. Inspection and Maintenance Schedule
9. Combustion Chart

1. General

This burner has been designed to provide many years of trouble free operation. The reliability can be greatly improved with some simple inspection and maintenance programs.

One of the best tools for a good maintenance program is to keep a log on the key parameters of the burner and boiler. These would include operating temperatures, pressures, inspections and preventative maintenance activities. This document can be used to detect any changes in the operating characteristics of the burner, which can be used for preventative maintenance.

The maintenance schedule can be used to help generate this log. There are also many other good references that can be use to help develop your log. Adding check points for other equipment into a common log can help. It is common to integrate the boiler and burner log, so that all components are checked at the same time.

The frequency of inspection given in the following charts is only a guideline. Initial results should be used to adjust the time intervals to be more frequent when problems or potential problems are observed.

2. Physical Inspection

Listening and looking at the burner can detect many problems. For example, leakage can usually be seen early with a small buildup of oil. Valve and linkage problems can usually be detected early on by simply watching the movement and detecting rough uneven changes. The jackshaft, linkage and valve movement should occur smoothly with no rough jerks.

The flame condition can often be a good indicator of the firing head. If the flame does not look correct, there may be a problem with the hardware. The firing head is exposed to the high temperatures of combustion and can have reduced life due to the thermal stress. In particular, the diffuser, oil nozzle, gas spuds, gas manifold, refractory and burner mounting plate should all be inspected.

3. Fuel-Air-Ratio Controls

The fuel-air-ratio controls must be maintained in good operating condition. Over time, these items will wear and may not

operate smoothly. Corrective action must be taken.

There are several different types of controls and the corrective action of each could be different. The following general guidelines can be used for initial steps.

Linkage based controls should be inspected for wear. If there is any noticeable play in the linkage rod ends or shaft bearing, they should be replaced. Likewise, any control valves that exhibit sloppy or hard to turn movement should also be replaced.

Fuel cams should have adjusting screws that are held firmly in position and can not move due to normal vibrations. The moving parts must be in good condition with no noticeable wear or play. Worn connections will result in hysteresis and reduced combustion efficiency.

The cam and jackshaft should be visually checked on a frequent or daily basis for obvious problems, including free movement, no loose parts and correct position of components.

On a monthly basis, the linkage and cams should be inspected for wear and loose parts. Also, observe the operation of the damper, FGR valve and fuel valves to insure they are working freely.

Annually, the cam and linkage should be operated manually to check the movement of all components and valves. Any worn parts should be replaced immediately.

If the burner will be operating for extended periods on gas, the oil gun should be removed to prevent the oil nozzles from "coking" due to the heat of the gas flame.

4. Gas Fuel System

The safety interlocks must be checked at regular intervals to ensure that they provide the proper safety. See the Inspection and Maintenance Schedule Chart (Figure 8) for frequencies.

The drip leg should be cleaned annually.

Monitoring the outlet gas pressure from the regulator will verify this control is working properly.

5. Oil Fuel System

The oil system has additional components that require regular maintenance, depending on the type of system used.

- a. Oil added to air compressor. The air compressor has a visual sight glass showing the oil level. This must be inspected every shift (while operating).
- b. Air compressor belt tight and in good condition

c. The oil strainer should be checked and cleaned periodically. A high vacuum reading on the suction side of the pump (over 10") is a good indication that the strainer needs to be cleaned. Strainers provided by Webster will use a wire mesh basket inside a canister. After turning the pump off (and making sure there is no pressure on the strainer), unscrew the yoke to gain access to the basket. The canister does not need to be drained. Be careful with the gasket when removing or replacing the cover to insure a good seal. The basket can be lifted out and cleaned with a soft brush and cleaning solution.

d. Vacuum within the 10" limit on suction side of pump (indicates need to clean strainer, as described above). If cleaning the strainer does not resolve this, check the other valves between the tank and gauge for plugged or closed position.

e. Oil nozzles should be cleaned periodically, depending on the type of operation and the observed need for cleaning. Extended operation at very low rates (less than 15% of capacity) can cause carbon buildup on the outside of the nozzle. This can be cleaned with a rag and cleaning solution. If the fire is showing some deterioration, and the external surfaces are clean, then the nozzles should be removed, disassembled and cleaned using a soft brush and cleaning solution.

f. If the edges of the oil nozzle are not sharp, or the nozzle shows sign of wear and the combustion is deteriorated, the nozzle should be replaced. The nozzle part number is given on the material list of the unit.

g. Check safety limits, including pressure and temperature switches

6. FGR Systems

The flue gas is corrosive and requires regular inspection of the equipment to ensure proper and safe operation. The potential for corrosion and frequency of the inspection can vary greatly based on the application. Applications with condensation will have more corrosion and will need more maintenance. Frequent cycling, cold startups, cool operating temperatures, cool air temperatures and outdoor installations are good examples of where high levels of condensation can occur.

Areas to inspect for corrosion:

- FGR control valves (s)
- FGR Duct
- Air inlet louver box
- Fan and fan housing
- Burner housing
- Firing head and blast tube

Other checks:

a. The condensation traps must work properly and be installed to capture all of the condensation. If condensation passes through to the burner windbox, a condensate drain should be added to the bottom of the windbox.

b. Linkage and valve movement must operate freely and smoothly.

c. If the FGR valve is modulated partly open (oil firing on dual fuel burner) check position of FGR valve.

d. NOx emissions level.

e. Other general items like refractory.

f. Stack temperature of boiler – high temperatures will increase NOx levels.

g. Operation of safety equipment.

h. Time delay on FGR on-off valve (if equipped).

7. Combustion air Fan

If the fan and motor are ever removed, there are special assembly procedures that must be followed for each type of fan to properly re-install the fan. Contact Webster for specific details.

Some common considerations are,

a. There should be about 1/4" overlap of inlet cone and fan.

b. Never re-use the fan to motor shaft set screws, always use new screws of the same size and style to maintain balance and fan retention.

c. When tightening the fan hub set screws, rotate the fan to place the screws on the bottom. This way the screw is not lifting the fan.

d. The motor shaft and fan hub must be clean and free of burrs.

e. Taper lock hub bolts must be tightened in a uniform manner, with several passes to obtain the full torque.

f. The set screws or taper lock bolts must be tightened to the torque specifications for that screw or bolt.

g. The key must be able to slide in the keyway by hand, and can not have any side play.

h. On some taper lock units, the key is locked in place by setting the surrounding material. In all cases, it must be secured.

8 - Inspection and Maintenance Schedule

Frequency						Component / Item	Recommended Action or Test	Performed By	
Daily	Weekly	Monthly	Seasonal	Annual	Annual As Required			Boiler Operator	Trained Burner Technician
X						Burner Flame	Visual inspection of burner flame.	X	
X						Jackshaft and Linkage	Visual inspection for smooth and free travel.	X	
X						Air Damper & register	Visual inspection for smooth and free travel.	X	
X						Fuel Metering Valves	Visual inspection for smooth and free travel.	X	
X						Draft Controls (Stack)	Visual inspection for smooth and free travel.	X	
X						Gas Fuel Pressure	Record in log book, compare trends.	X	
X						Oil Pressure	Record in log book, compare trends.	X	
X						Atomizing Air Pressure	Record in log book, compare trends.	X	
X						Pilot	Visually inspect pilot flame, check and record flame signal strength if metered.	X	
	X					Flame SafeGuard - Pilot Test	Close manual fuel valve on pilot during cycle and check for safety shutdown, recording time.	X	
	X					Flame SafeGuard - Main Flame	Close manual fuel valve on pilot during cycle and check for safety shutdown, recording time.	X	
		X				Flame SafeGuard	Check flame safeguard components, including scanner.		X
				X		Flame SafeGuard	Replace flame safeguard components in accordance with manufacturers instructions.		X
				X	X	Pilot Turndown Test	Conduct pilot turndown test annually or after any component change.		X
				X	X	Hot Refractory Test	Conduct hot refractory hold in test. This test is required annually or after any component change.		X
		X				Oil Pressure and Temperature Interlocks	Check oil pressure and temperature switch for smooth operation and correct action.		X
		X				Atomizing Air Pressure	Check air atomizing pressure interlock switch for smooth operation and correct action.	X	
		X				Interlock Controls	Check other interlocks that may be used on the burner for smooth operation and correct action.		X
			X			Firing Rate Control	Check firing rate control and verify settings.		X
			X			Combustion Tuning	Conduct a combustion test, verify setting and NOx emission levels.		X
X						Pilot and Main Fuel Valves	Make visual and manual check for proper sequencing of valves.		X
				X		Pilot and Main Fuel Valves	Check all coils, diaphragms, interlock switch & other parts of all safety shutoff valves.		X
				X		Pilot and Main Fuel Valves	Perform leak tests on all safety shutdown control valves.		X
				X		Low Pressure Air Switch	Test low air pressure switch for proper operation and adjustment.		X
				X		Mod Damper Switch	Check damper low fire proving switch per manufacturers instructions.		X
				X		Linkage and Fuel Cams	Check linkage and cams for wear and replace any items with wear indication or stress cracks.		X
X						FGR Control Valve	Visual inspection for smooth and free travel.	X	
			X			FGR Control Valve	Clean and lubricate FGR control valve.	X	
	X					FGR Shutoff Valve	Visually inspect for smooth and complete travel.	X	
			X			FGR Shutoff Valve	Clean and lubricate FGR shutoff valve	X	
X						FGR Condensate Drain	Open FGR condensate drains, remove all condensate.	X	
					X	FGR Shutoff Valve Switch	Check operation of shutoff FGR valve for full rotation and position proving switch.		X
					X	FGR Duct	Inspect and clean FGR duct.	X	
					X	Combustion Air Fan	Clean combustion air fan and housing		X
X	X					Burner Components	Visually check the burner components for signs of cracks, deformation, slippage or other unusual indication.		X
		X				Burner Mounting	Check burner mounting clamps and brackets for tightness.	X	
		X				Refractory and Seals	Check burner refractory for cracks or signs of leakage.	X	
		X				Oil Nozzle	Check and clean oil nozzle.	X	
X						Air Compressor	Check air compressor for lubrication oil and air filter.	X	
					X	Air Compressor	Check air compressor relief valve operation.		X

9 - Combustion Chart

This graph shows the relationship between excess air, %Oxygen and %CO₂, which is typically obtained from a flue gas analyzer. The values are based on a dry reading, where the flue gas is extracted and cooled before the analysis if done.

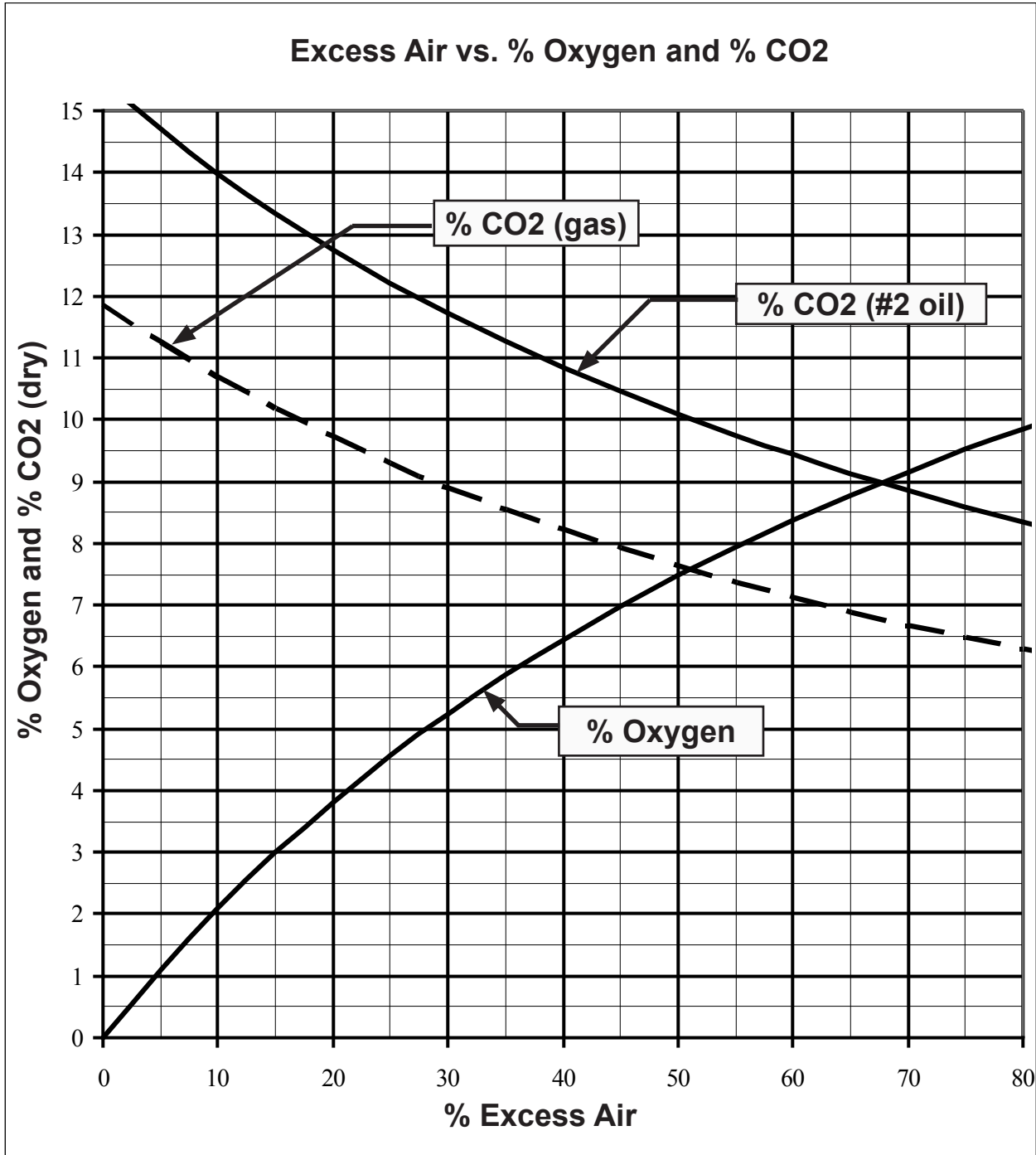

NOTES

H. Troubleshooting

No.	System	Cause	Correction
1	No Ignition (lack of spark)	Electrode is grounded. Porcelain is cracked.	Replace
		Improperly positioned electrode	Recheck dimensions
		Loose ignition wire connection	Reconnect or tighten
		Defective ignition transformer	Check transformer, replace
2	No Ignition (spark, no flame)	Lack of fuel, no gas pressure, closed fuel valve	Check fuel supply and valves
		No voltage to pilot solenoid	Check electrical connections
		Defective pilot solenoid valve	Replace
		Incorrect location of pilot	Check location of pilot
		Improper raw gas tube position	Check location of raw gas tube
		Improperly positioned electrodes	Recheck dimensions
		Too much combustion air flow	Check air damper position
3	Pilot not detected (flame present)	Scanner tube not positioned correctly	Check location of scanner tube
		Scanner tube dirty	Clean scanner tube
		Scanner or amplifier faulty	Replace
		Pilot improperly positioned	Check pilot position
		Incorrect gas pressure to pilot	Readjust pressure
		Combustion air flow rate too high	Readjust damper
4	No main gas flame (pilot OK)	Weak scanner signal	Clean scanner lens and tube
		Damper or fuel control valve setting incorrect	Readjust
		Fuel valve(s) not opening	Check wiring to valves
		Closed Fuel Valve	Check Manual Gas Valve
5	No main oil flame (pilot OK)	Weak scanner signal	Clean scanner lens and tube
		Damper or fuel control valve setting incorrect	Readjust
		Fuel valve(s) not opening	Check wiring to valves
		Oil nozzle or line obstructed	Check nozzle and lines, clean
		No atomizing air pressure	Check compressor wiring
		Compressor pressure too low or high	Readjust
		Burner not level, oil is draining into vessel	Check level, adjust as required.
6	Burner stays at low fire	Manual pot in low fire position (low fire hold)	Readjust to high fire position
		Manual-auto switch in wrong position	Change position of switch
		Modulating Control	Check wiring or replace
		Loose linkage	Readjust and tighten
		Binding linkage or valve	Readjust or replace
7	Burner shuts down during operation	Loose electrical connection	Check and tighten connections
		Loss of fuel supply	Replenish fuel supply
		Limit switch breaks (opens)	Readjust limit switch
8	Burner does not start	Main disconnect switch is open	Close switch
		Loose electrical connection	Check electrical connections
		Operating controls are tripped	Check and reset operating limits
		High or low fuel pressure	Check fuel supply - reset switches
9	High CO at low fire (firing gas)	Improper excess air level	Readjust excess air
		Input too low for burner components	Check input, compare to rating label

No.	System	Cause	Correction
	High CO at low fire (con't)	High stack draft (especially at low fire)	Stabilize draft
	(firing gas)	Poor air flow distribution (off center flame)	Adjust air register position
		Diffuser not in optimum position	Adjust diffuser position in or out
		Fluxuating gas pressure (regulator not holding pressure)	Check regulator pressure, sensing line and supply pressure: sized properly
10	Gas combustion noise	Input too low for burner components	Check input, compare to rating label
	(rumbling)	Improper excess air	Readjust excess air
		Fluxuating gas pressure (regulator not holding pressure)	Check regulator pressure and supply
		High stack draft (especially at low fire)	Stabilize draft
		Diffuser not in optimum position	Adjust diffuser position in or out
		Poor air flow distribution (off center flame)	Adjust air register position
11	Oil combustion smoking	Oil nozzle dirty or plugged	Clean oil nozzle
		Improper excess air	Readjust excess air
		Input too low for burner components	Check input, compare to rating label
		High stack draft (especially at low fire)	Stabilize draft
		Incorrect nozzle position	Adjust the nozzle to diffuser position
		Fluxuating oil pressures (regulator not holding)	Check regulator pressure and oil supply
		Poor air flow distribution (off center flame)	Adjust air register position
		Too much FGR (if equipped)	Reduce FGR rate
12	Fuel-Air-Ratios are	Linkage flexing	Realign linkage, straighten rods
	not consistent	Linkage slip	Check linkage and tighten all joints
		Fuel cam screws have moved	Replace fuel cam
		Fuel line plugged	Check and clean lines, strainers & filters
		Fuel supply pressure changing	Check and/or replace pressure regulator
		Combustion air temperature changed	Retune burner
		Draft condition changed	Check draft and outlet damper
		Plugged or leaky FGR line	Clean / repair
		Gas control valve - low fire stop not set	Adjust low fire stop
13	Fuel-Air-Ratios have changed	Linkage wear	Check linkage and tighten all joints
	over time	Fuel cam screws have moved	Replace fuel cam
		Air damper seal worn	Replace air damper seals
		Fuel lines plugged	Check and clean lines, strainers & filters
		Fuel control valve worn	Replace fuel control valve
		Gas orifices or gas manifold plugged	Clean and/or replace
		Combustion air temperature changed	Retune burner
		Draft condition changed	Check draft and outlet damper
		Vessel plugged	Clean vessel
		Plugged or leaky FGR valve	Clean / repair
14	Cannot obtain capacity on	Wrong spring range in regulator	Install higher spring range
	gas	Too many elbows before control valve	Rework piping to reduce elbows
		Gas line too small, high pressure drop	Use larger pipe size
		Supply pressure lower than stated	Increase supply pressure
		Supply pressure drops too low at high fire	Use larger gas line sizes / orifice in service regulator
		Regulator too small for flow and pressure	Change regulator
15	Cannot obtain rated input on	Oil nozzles plugged	Replace nozzles
	oil firing (pressure atomized)	By-pass seal on nozzle leaking	Replace nozzles

No.	System	Cause	Correction
	Cannot obtain rated input on	Oil pressure too low	Increase oil pressure
	oil firing (pres. atom.) (con't)	Flow valve set too low (should be closed at high fire)	Adjust oil control valve
		Oil flow valve set too low (should be closed at high fire)	Adjust oil control valve
16	Cannot obtain rated input on	Oil nozzles plugged	Replace nozzles
	oil firing (air atomized)	Air pressure too low	Replace nozzles
		Oil pressure too low	Increase oil pressure
		Flow valve set too low	Adjust oil control valve
17	Cannot obtain NOx levels on	Inlet tube in wrong position	Adjust inlet tube to center of fan inlet
	gas	" "	Taper FGR valve to be full open
		FGR valve not full open	Adjust FGR valve to full open
		FGR valve full of condensate	Clean duct and add drains
		FGR duct not directed to flue stream	Add angle cut in center of stack
		FGR line too small	Check sizing, use fittings with less drop
		Operating on propane, not natural gas	Resize FGR for propane operation
		Shutoff valve is not full open	Check FGR shutoff valve position

NOTES

WARRANTY MATTERS AND EXCLUSION OF IMPLIED WARRANTIES

The following warranty applies: All Products manufactured by the Company are warranted to be free from defects in material and workmanship under normal use and service for a period of eighteen months from the date of shipment or twelve months from the date of start-up; whichever should occur first. Products which are purchased by the Company and resold without further processing by the Company are not covered by the Company's warranty. The Company shall pass to the Buyer whatever warranty the Company receives on such products. The Company will repair or replace, at its option, its products which prove to be defective within the warranty period, F.O.B. the factory. The Company's warranty shall be voided by any abuse, misuse, or neglect of the products by use not in accordance with the Company's published instructions. The remedies for any failure of the Company's product to meet warranty specified herein shall be those remedies herein and no others; these remedies being exclusive remedies as a condition of sale irrespective of the theory upon which any claim might be based, including negligence, breach of contract or strict liability.

IN ALL EVENTS, THE COMPANY WILL NOT BE LIABLE FOR AND WILL NOT REIMBURSE ANY LABOR, MATERIAL, OR OTHER REPAIR CHARGES INCURRED BY ANYONE OTHER THAN THE COMPANY ON ANY WARRANTY EQUIPMENT, UNLESS SUCH CHARGES HAVE BEEN SPECIFICALLY AUTHORIZED IN ADVANCE IN WRITING, BY THE COMPANY. THIS PARAGRAPH CONTAINS THE COMPANY'S SOLE WARRANTY. THE COMPANY MAKES NO IMPLIED WARRANTY, AND THERE IS NO IMPLIED WARRANTY OF MERCHANTABILITY OR FITNESS FOR ANY PARTICULAR PURPOSE.

DAMAGE LIMITATION

Under no circumstances shall the Company be liable for any loss of profits, down time, or any incidental, consequential, special, punitive, exemplary, enhanced, or indirect damages of any kind with respect to its products or the transaction by which its products are sold.

IN NO EVENT SHALL THE COMPANY'S AGGREGATE LIABILITY ARISING OUT OF OR RELATED TO THE EQUIPMENT OR THE TRANSACTION BY WHICH THE EQUIPMENT IS SOLD, WHETHER ARISING OUT OF OR RELATED TO BREACH OF CONTRACT, TORT (INCLUDING NEGLIGENCE), OR OTHERWISE, EXCEED THE TOTAL OF THE AMOUNTS PAID TO THE COMPANY WITH RESPECT TO SUCH EQUIPMENT.

EXCUSE

In no event shall the Company be liable for any loss or damage resulting from any delay or failure in shipment or other failure, loss or damage that is the proximate result of any act of government authority, revolution, riot, civil disorder or disturbance, act of enemies, delay or default in transportation, inability to obtain materials or facilities from normal sources of fire, flood, act of God, or any cause not within the reasonable control of the Company, whether of the class of causes enumerated or otherwise. Without limiting the generality of the foregoing, the Company may, without causing a breach or incurring liability, allocate goods which are in short supply irrespective of the reasons therefore among customers in any manner which the Company in its sole discretion deems advisable. If an event occurs that is beyond the control of the Company's performance and causes its cost of production to increase because of the delay, the Company may pass such increase on to the Buyer.



WEBSTER COMBUSTION TECHNOLOGY
619 Industrial Road - Winfield, KS 67156
Phone 620-221-7464 Fax 620-221-9447

sales@webstercombustion.com service@webstercombustion.com
www.webstercombustion.com