

JB(X) HT Series Burners

**Efficient, Reliable, Safe, High Turndown
Solutions For Cast Iron, Firetube, Firebox,
Watertube And Process Applications**



10 BHP to 300 BHP Range

Benefits Of The JB and JBX HT Series

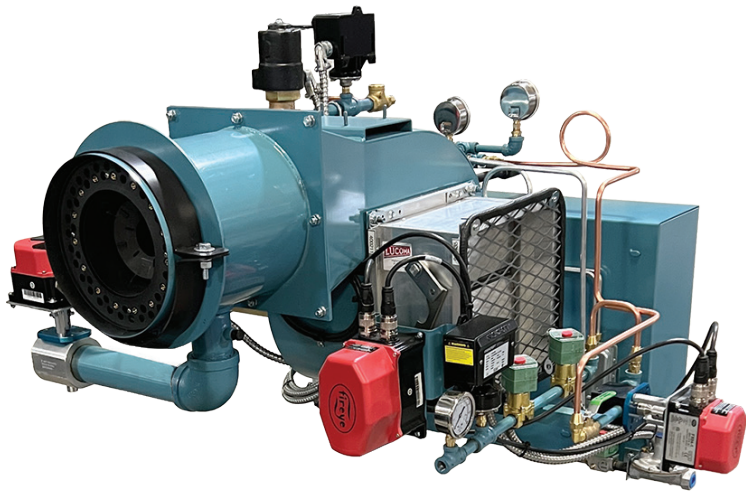

Webster JB(X) HT series burners offer years of dependable, efficient operation for high turndown applications. Designed with ease of serviceability in mind, Webster burners are equipped with a wide variety of the latest control and technology options available. The JB(X) HT series burner is one of the most efficient burner options in the industry, with up to 10:1 turndown available when firing gas, and 8:1 firing oil.

Versatility and flexibility are prime considerations in the Webster JB(X) HT series design. JB(X) HT units can be adapted to fire in most any furnace configuration or combustion environment, and Webster has years of proven experience firing a multitude of fuels including: Natural, LP, and Digester gas, No.2 through No. 6 oil, and other more exotic fuels.

Webster JB(X) HT series burners are completely factory wired, assembled, and tested so they come to you ready for installation and connection to fuel and electrical supplies. Typical JB(X) HT series burners are installed and ready for start-up in a minimal amount of time, saving valuable time and money at your installation.

When it comes to low emission requirements, Webster should be your choice. The JB HT burner is available with Induced FGR for applications requiring 30ppm NO_x emissions. Webster has been providing low emission units for more than 30 years and understands what it takes to meet your compliance requirements.

JB and JBX HT Burner Features

Versatile

- Up to 10:1 turndown firing gas and up to 8:1 turndown firing No.2 Oil
- Available in multiple housing and control panel configurations
- Fires multiple fuels
- Designed for all types of boilers, heaters and furnaces
- Proven performance in all types of applications

Reliable

- Outstanding flame stability
- High combustion efficiency
- Designed for ease of service
- Quiet operation
- UL & ULC Listed

Adaptable

- Standard or inverted housing
- Burner mounted or remote control panels
- Standard or low NOx designs available

Efficient

- Linkageless control options
- Add Temp A Trim for most efficient operation and quick payback



Webster Combustion has the best lead times in the industry. To configure the perfect JB(X) HT burner for your application and obtain current scheduling information, contact Webster or visit www.webstercombustion.com to locate a sales office in your area.

JB(X) HT Series Maximum Input Capacity Ratings

Burner Model	Min Req'd Gas Pressure	Standard Gas Train Size	Max Firing Rate (MBH) Standard	Max Firing Rate (MBH) w/FGR	Fan Motor HP
JB(X)1*02HT	6" wc	1"	1,000	800	1/4
JB(X)1*03HT	8" wc	1-1/4"	1,500	1,200	1/3
JB(X)1*05HT	8" wc	1-1/2"	2,100	1,680	1/2
JB(X)1*07HT	11" wc	1-1/2"	2,500	2,000	3/4
JB(X)2*07HT	13" wc	1-1/2"	2,800	2,240	3/4
JB(X)2*10HT	14" wc	2"	3,500	2,800	1
JB(X)2*15HT	14" wc	2"	3,500	2,800	1-1/2
JB(X)2*20HT	14" wc	2"	4,200	3,360	2
JB(X)2*30HT	14" wc	2-1/2"	5,300	4,240	3
JB(X)2*50HT	18" wc	2-1/2"	6,000	4,800	5
JB(X)3*30HT	1 psig	2-1/2"	6,300	5,040	3
JB(X)3*50HT	1 psig	3"	8,300	6,640	5
JB(X)3*75HT	1 psig	3"	10,500	8,400	7-1/2
JB(X)3*100HT	1.5 psig	3"	12,600	10,080	10

* Can be "G"(Gas), "O" Oil, or "C" (Combination Gas/Oil)

JB(X) HT Series Typical Dimensions (Inches)

Model	A	B1	B2	C1	C2	D	E	F**	G**	H1***	H2***	L1	L2	W***	X**
JB(X)1*HT	2.5	18.375	18.375	8.25	14.375	7.25	11.438	18.938	5	15.688	11.375	26.625	36.938	21.875	13.75
JB(X)2*HT	2.5	19.063	18.5	9.5	14	9.125	17.75	20	6.625	19	12.125	28.625	39.25	30.688	24.25
JB(X)3*HT	2.5	19.938	19.563	15.313	19.25	11.25	23.25	26.938	8.313	22.5	14.75	38.25	48	36.75	29.5

* Add 1/4" to Dimension L1 for heavy oil burners. Use Dimension L2 for alternate control cabinet location. ** On units with FGR for NOx reduction, FGR valve will emerge from side of burner opposite blower motor. *** Extra ground clearance & width may be required for the addition of FGR. Consult factory for details.

JB(X) HT Standard Arrangement

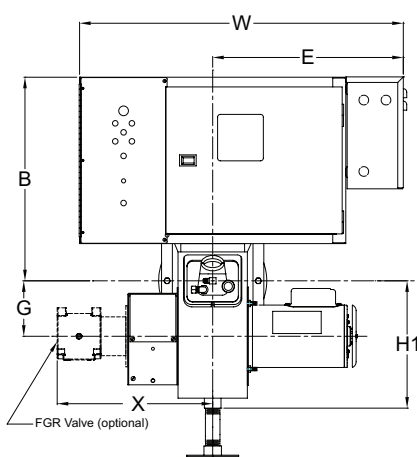

JB(X) HT Inverted Arrangement (Optional)

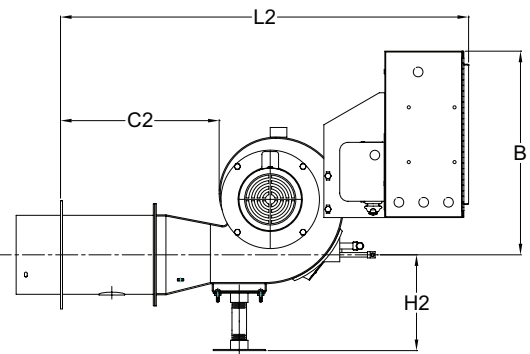

Represented By

The Better Burner.

619 Industrial Road, Winfield, KS 67156 / Phone: 620-221-7464 / Fax: 620-221-9447

www.webstercombustion.com / sales@webstercombustion.com