

JBFX/HDFX Series Burners

Proven Ultra Low NOx Performance

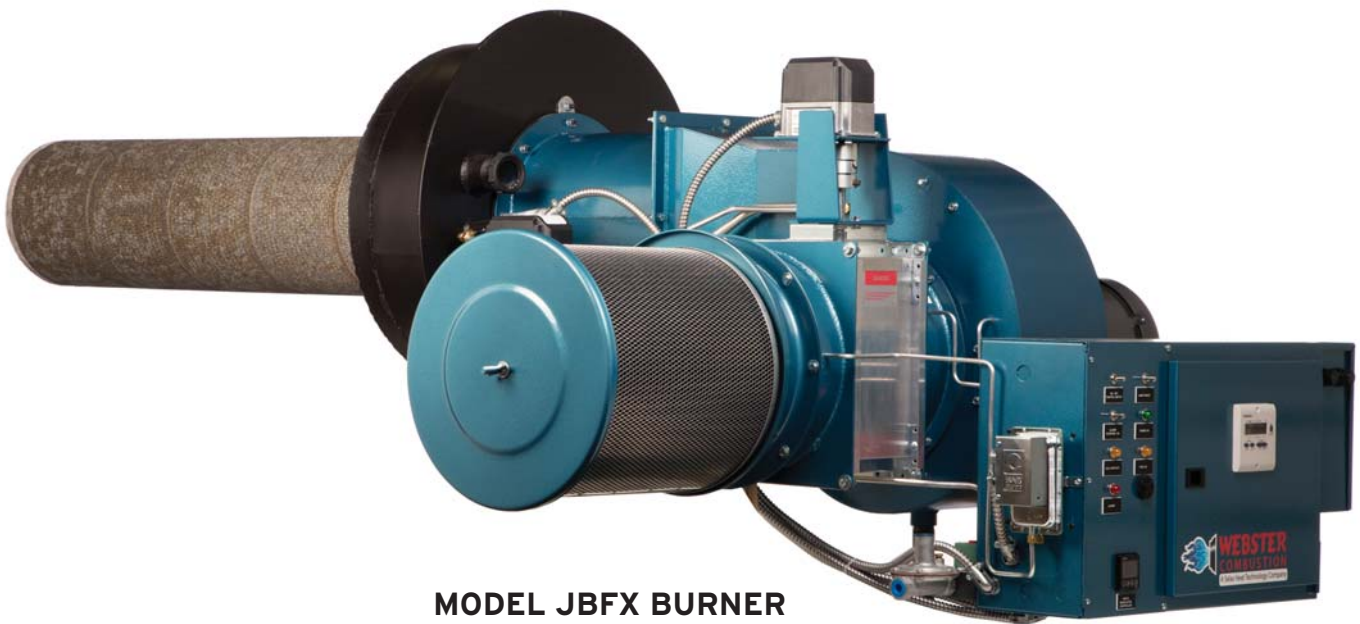

MODEL JBFX BURNER

Range from 10HP up to 500HP

Benefits of the JBFX/HDFX Series Burners

With the introduction of the JBFX and HDFX series burners, Webster has added the ability to achieve single digit NOx emissions without the use of Flue Gas Recirculation (FGR). The new JBFX and HDFX burners utilize fiber mesh, surface combustion technology that covers a range from 10HP up to 500HP. The JBFX and HDFX operate by premixing fuel and air to precise levels, which ensures complete combustion with very low levels of CO and unburned hydrocarbons. The JBFX/HDFX firing head is made of a proven all metallic fiber mesh that guarantees long lasting, reliable performance.

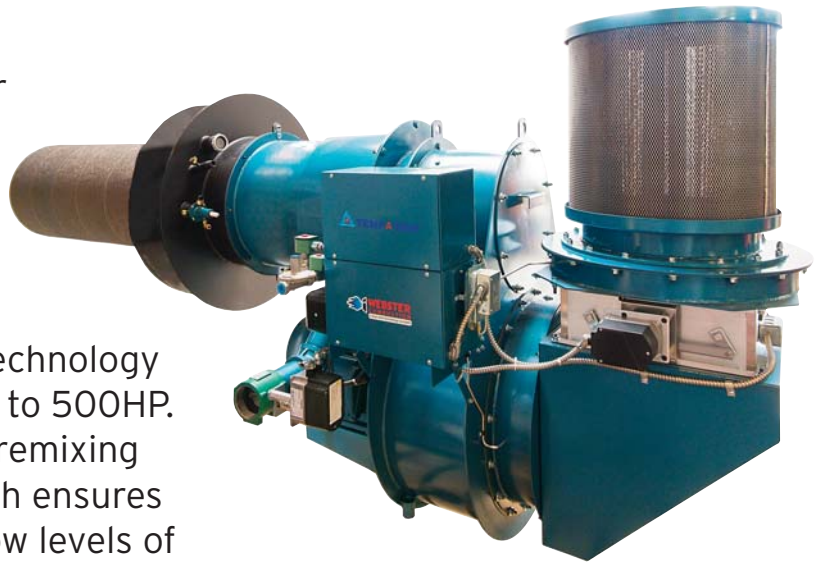

MODEL HDFX BURNER

Suitable for use on firetube and watertube boilers, process heaters, and many other applications, the "FX" line of Webster burners will operate with stability and dependable heat transfer in a wide range of operating conditions. Webster's ultra-low NOx burners come standard with a parallel positioning control system to provide precise control of fuel and air and keep your burner operating safely and efficiently. In addition, the integral blower and burner-mounted control panel on the JBFX allow the operator easy maintenance and the owner a low investment.

Webster JBFX/HDFX burners come to you ready for installation and connection to fuel and electrical supplies for quick start-up, saving time and money at your facility. In addition, Webster JBFX and HDFX burners offer turndowns of up to 8:1, which means less cycling, less maintenance, increased efficiency, and increased savings in your boiler room.

Combining the JBFX/HDFX burner with Webster's patented Temp A Trim air density trim system provides even more savings and affords the quickest payback of any burner in the industry, as well as the opportunity for energy rebates. In addition, the use of Webster's Temp A Trim system provides a further guarantee that NOx levels will stay in compliance regardless of changing seasons or operating conditions in the boiler room.

JBFX/HDFX Features

- Single digit NOx emissions - guaranteed
- No need for Flue Gas Recirculation (FGR)
- Fiber mesh, surface combustion technology
 - ✦ Low levels of CO or unburned hydrocarbons
- U.L. listed
- Turndown up to 8:1 available
- Heavy duty, industrial construction
- Designed for ease of service and maintenance
- Quiet operation
- Standard or inverted mounting options available
- Burner mounted or remote control panels
- Linkageless controls - standard
- Add Temp A Trim for:
 - ✦ Most efficient operation
 - ✦ Quickest payback
 - ✦ Even lower emissions



HDFX BURNER INSTALLATION

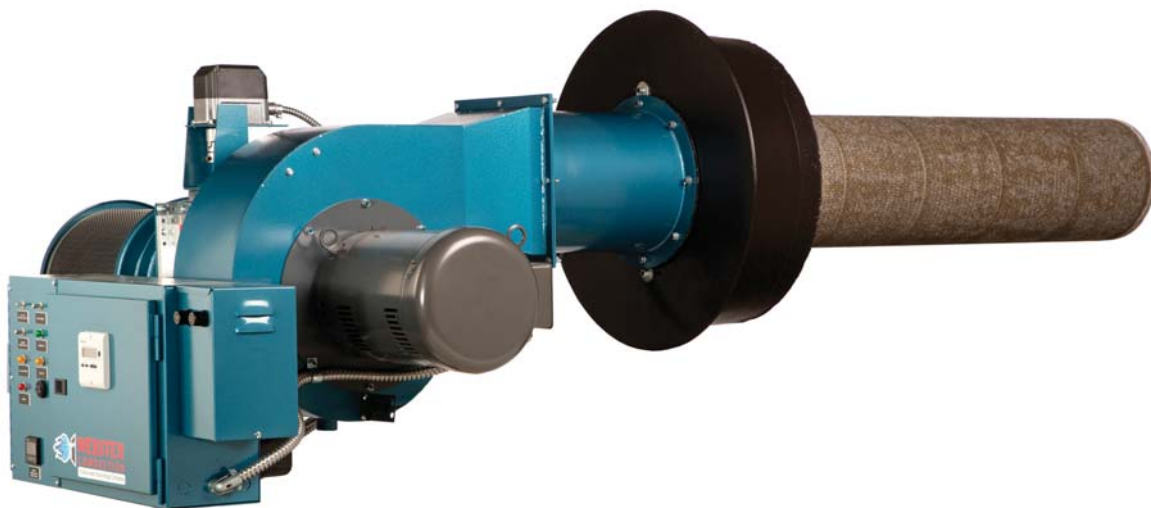

Webster Combustion has the best lead times in the industry. To configure the perfect JBFX/HDFX burner for your application and obtain current scheduling information, contact Webster or visit www.webstercombustion.com to locate a sales office in your area.

JBFX/HDFX Series Typical Dimensions (Inches)

Burner Model Number	Input (MBH)	Motor HP	Std. Gas Train Size	Min. Req'd Gas Pres.	Dimensions							
					A	B	C	D	E	F	G	H
JBFX1-G10-03	420	1/3	1"	1 PSIG Min.	4	6	24.4	12.3	11.5	20	30.5	10.6
JBFX1-G15-03	640	1/3	1"	Req'd Supply	4	9	24.4	12.3	11.5	20	30.5	10.6
JBFX1-G20-05	850	1/2	1"	Pressure	5.3	9	24.4	12.3	11.5	20	30.5	10.6
JBFX1-G25-05	1060	1/2	1"	↓	7.6	8	24.4	12.3	11.5	20	30.5	10.6
JBFX1-G30-07	1280	3/4	1 1/4"		7.6	9.5	24.4	12.3	11.5	20	30.5	10.6
JBFX1-G35-07	1490	3/4	1 1/4"		7.6	11	24.4	12.3	11.5	20	30.5	10.6
JBFX1-G40-07	1700	3/4	1 1/4"		7.6	12.6	24.4	12.3	11.5	20	30.5	10.6
JBFX1-G42-10	1790	1	1 1/4"		7.6	13.1	24.4	12.3	11.5	20	30.5	10.6
JBFX1-G47-10	2000	1	1 1/2"		7.6	14.8	24.4	12.3	11.5	20	30.5	10.6
JBFX2-G50-15	2130	1 1/2	1 1/2"		7.6	15.5	23.5	14.3	14.8	20	33.6	10.6
JBFX2-G60-15	2560	1 1/2	1 1/2"		7.6	19	23.5	14.3	14.8	20	33.6	10.6
JBFX2-G75-20	3200	2	2"		7.6	23.5	23.5	15.3	14.8	20	33.6	10.6
JBFX2-G90-30	3840	3	2"		9.5	23	23.5	15.3	14.8	20	39.6	11
JBFX3-G100-50	4260	5	2"	9.5	26	33.9	16	18.5	20	40.2	11	
JBFX3-G125-50	5330	5	2 1/2"	9.5	31	33.9	16	18.5	20	40.2	11	
JBFX3-G150-100	6400	10	2 1/2"	11	33	33.9	20	18.5	20	40.2	11	
JBFX3-G200-100	8530	10	3"	11	44	36.5	20	18.5	20	40.2	11	
HDFX5-G250-150	10,500	15	3"	2 PSIG	13	46	15.3	15.3	36	22.6	54	18
HDFX5-G300-150	12,600	15	3"	2 PSIG	15	48	15.3	15.3	36	22.6	54	18
HDFX7-G500-300	20,900	30	3"	4 PSIG	20	48	17.9	17.9	39.5	23.4	77.3	26.5

Note: HDFX burners are not currently U.L. listed.

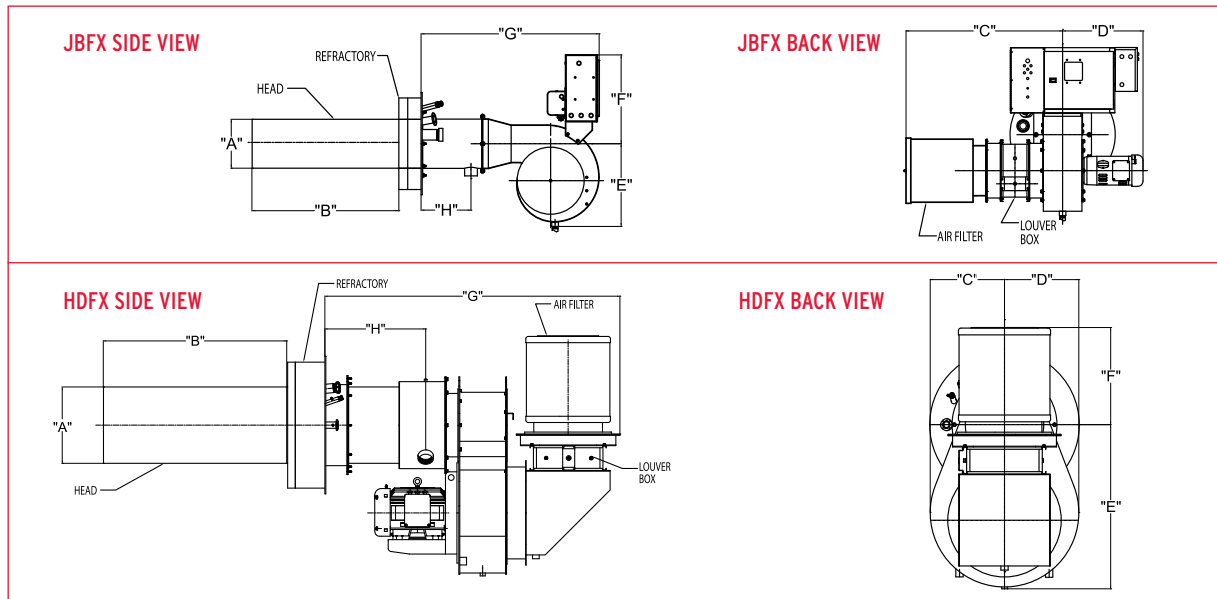

The Better Boiler Burner.

Represented By

619 Industrial Road, Winfield, KS 67156/Phone: 620-221-7464/Fax: 620-221-9447
www.webstercombustion.com /sales@webstercombustion.com