

SG Series Burners

**Compact, Economical Gas Burners for
Small Boilers and Hot Water Heaters**



For Firing Rates from 300 up to 2,500 MBH

Benefits Of The SG Series Burner

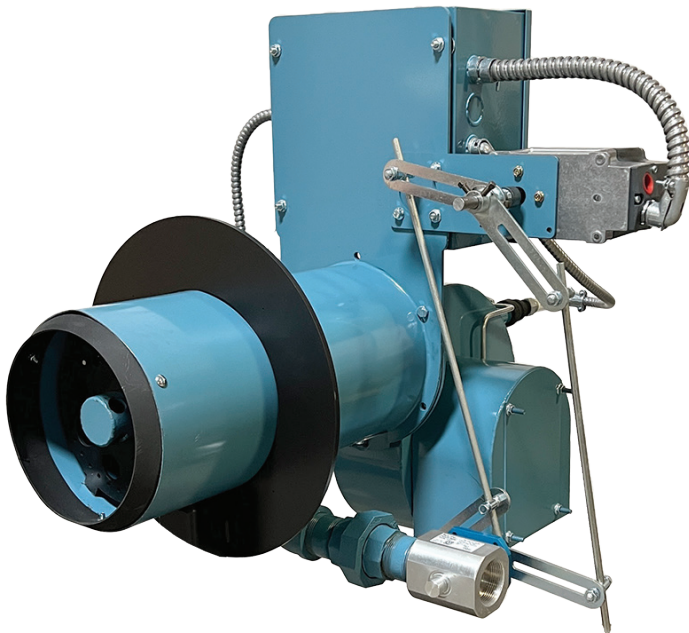

The Webster SG series straight gas burners are designed to offer years of dependable and economical operation. Built with economy in mind, Webster SG burners are durable and easy to start up and service. Our exclusive flame retention head design maintains stable and efficient combustion in a wide variety of furnace configurations and conditions.

The SG burner features a swing-away housing for ease of maintenance and adjustments.

Webster SG burners are completely factory wired, assembled, and tested so they come to you ready for installation and connection to fuel and electrical supplies. Typical SG series burners are installed and ready for start-up in a minimal amount of time, saving valuable time and money at your installation. Due to standardized SG configurations and the responsiveness of the Webster factory, you can get an SG in no time when you need one!

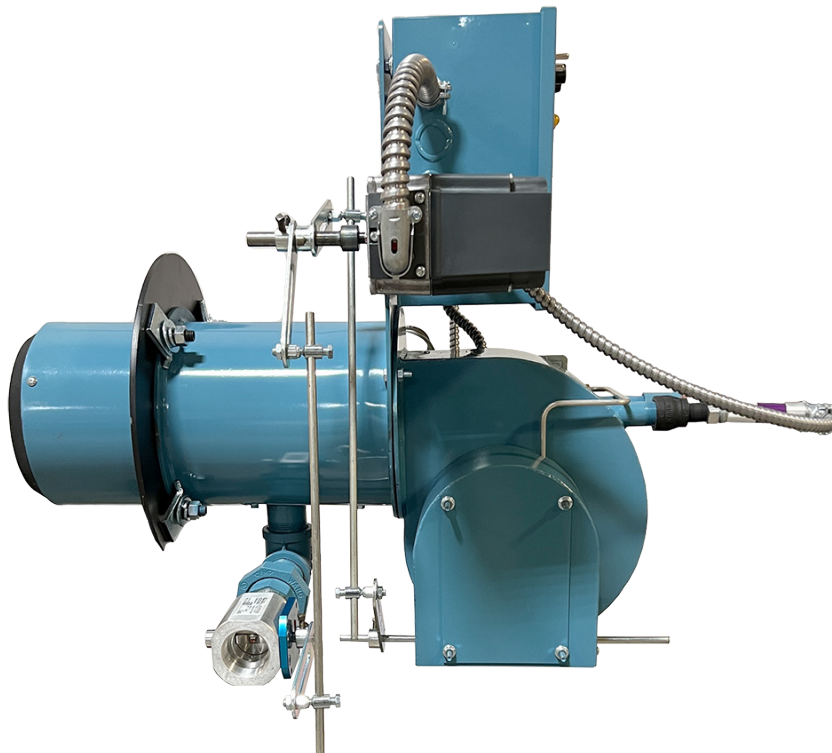

SG Series Burner Features

Versatile

- Fires multiple applications with the same burner configuration
- Fires Natural or LP Gas
- Designed for all types of boilers, heaters and furnaces
- Proven performance in many applications

Reliable

- Outstanding flame stability
- Designed for ease of service
- Quiet operation
- Ultra-violet flame scanner
- UL & ULC Listed

Adaptable

- 300 to 2,500 MBH firing rate
- Upright housing
- On-Off, Low Fire Start, Low-High-Low, or Modulating operating modes



Webster Combustion has the best lead times in the industry. To configure the perfect SG burner for your application and obtain current scheduling information, contact Webster or visit www.webstercombustion.com to locate a sales office in your area.

SG Series Typical Dimensions (Inches)

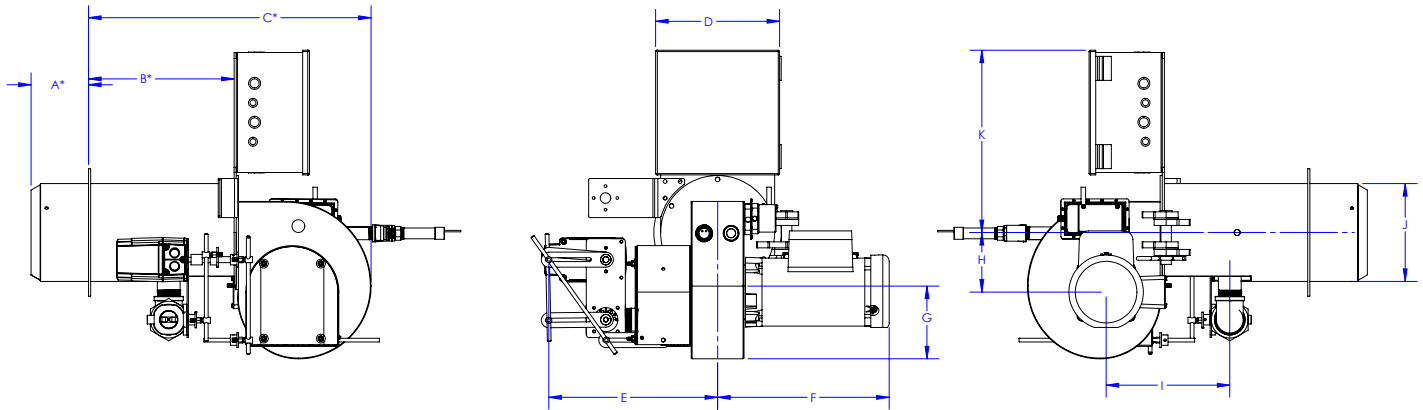

Burner Model	A*	B*	C*	D	E	F	G	H	I	J	K
SG6	4	12.1	23.5	10.3	14.1	14.3	6.1	5.0	10.3	6.1	13.0
SG8	4	12.1	23.5	10.3	14.1	14.3	6.1	5.0	10.3	8.1	13.0

* Based on standard burner insertion. For insertion different from 4", contact Webster for dimensions. All dimensions are for reference only. Webster reserves the right to change dimensions without notice.

SG Series Maximum Input Capacity Ratings

Burner Model	Min Req'd Gas Pressure	Standard Gas Train Size	Max Firing Rate (MBH) Standard	Fan Motor HP
SG6-03	6" wc	1"	1,000	1/3
SG8-03	8" wc	1-1/4"	1,500	1/3
SG8-05	8" wc	1-1/2"	2,500	1/2



The Better Burner.

619 Industrial Road, Winfield, KS 67156 / Phone: 620-221-7464 / Fax: 620-221-9447
www.webstercombustion.com / sales@webstercombustion.com

Represented By