

Twister™ Series Asphalt Plant Burners

Multi-Fuel Open-Fired Burners



Open-Fired Series Burner

For Firing Rates From 35,000,000 to 100,000,000 Btu/Hr

Benefits Of The Twister™ Multi-Fuel Burner



The Webster Combustion Twister series is an open-fired burner that allows the user to operate with high efficiency and extremely reliable performance to keep plants running and producing at a high level.

The Webster Combustion Twister series open-fired burner operates with lower motor HP requirements than our competitors and uses an integrally mounted fan, meaning users will enjoy energy savings and a more compact burner system. Optionally supplied VFDs and control systems are available to maximize turndown capabilities, increase fuel savings and reduce total energy usage.

The Twister series asphalt plant burners are capable of burning a wide range of fuels, either separately or simultaneously, including Natural, LP, and low BTU gases, all commercially available fuel oils, and qualified waste oils.

The Webster Combustion Twister is available in a wide variety of configurations. Webster's engineering team will assist you in designing the best arrangement for your specific application. Flexibility in design is a hallmark of Webster products and these asphalt plant burners can be applied to a wide variety of applications.

Twister™ Series Burner Features

- Excellent flame stability for reliable performance
- Fire multiple fuels
 - Natural and LP Gas
 - No. 2 through No. 6 Oil
 - Waste Oil
- Integral combustion fan
- Turndowns up to 8:1
- Proven ignition system with extremely stable pilot
- High efficiency combustion fans to optimize energy savings
- Optional VFD for precise control
- Compressed air atomization for oil firing
- The Twister can be controlled by the ACS-100 Asphalt Plant Burner Control System
- Works on Counterflow Asphalt Plants or Drum Mix Asphalt Plants (for hot mix batch flow)
- Also suitable for many rotary drying applications (sand, limestone, gravel, minerals, etc).

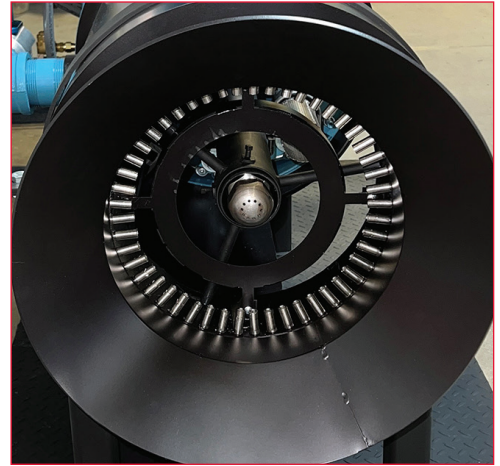

Webster Combustion has the best lead times in the industry. For assistance in selecting the proper configuration or to obtain a quote, please contact us or your local Webster aggregate products representative.

Twister™ Series Typical Dimensions and Ratings

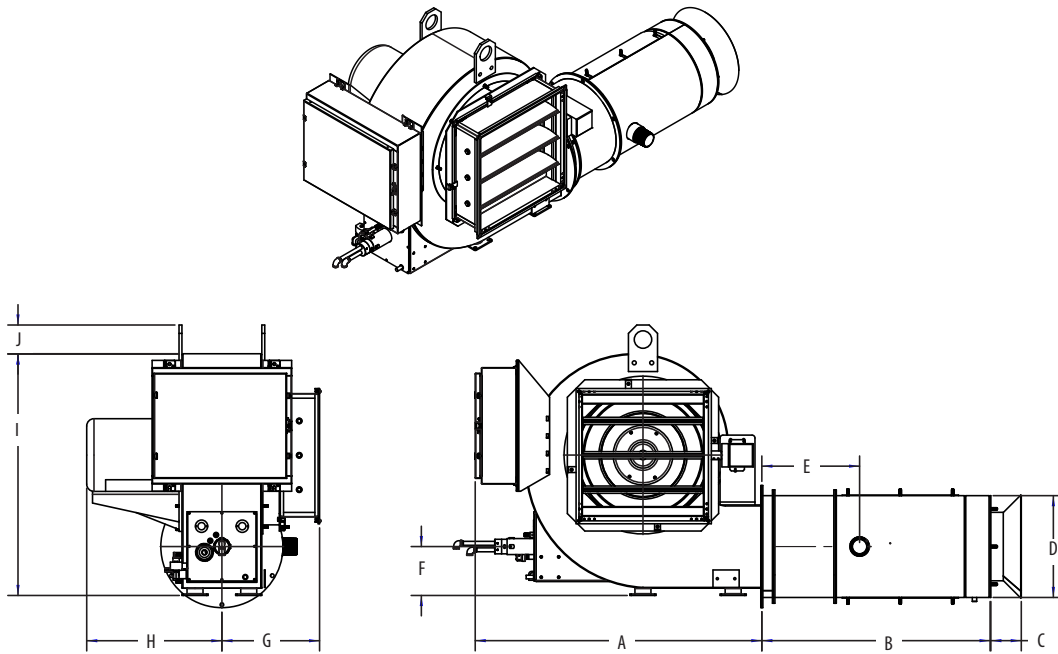

BURNER MODEL	FAN HP	FIRING RATE MBH	DIMENSIONS-INCHES									
			A	B	C	D	E	F	G	H	I	J
TW-35	20	35,000	49.3	40.0	5.5	15.0	16.8	7.5	16.8	23.2	41.5	4.9
TW-50	30	50,000	50.5	40.0	5.5	19.5	16.8	9.8	17.3	30.7	41.5	4.9
TW-75	50	75,000	54.6	40.0	5.5	21.8	16.8	10.9	19.8	33.2	41.5	4.9
TW-100	60	100,000	55.9	40.0	5.5	24.0	16.8	12.0	19.8	37.4	41.5	4.9

All dimensions shown are for reference only. Webster can change dimensions at any time without notice.



The Better Burner.

619 Industrial Road, Winfield, KS 67156 / Phone: 620-221-7464 / Fax: 620-221-9447
www.webstercombustion.com / sales@webstercombustion.com

Represented By